



# 2025 High Limit Sprint Car Series Rule Book © 2025

Date of Publication: February 2025

**Mike Hess – Series Director**  
[MHess@highlimitracing.com](mailto:MHess@highlimitracing.com)  
**217-341-0872**

## Table of Contents

A) Preface	4
1. Definition of Terms	4
2. High Limit Sprint Car Series Rules:	6
B) Membership	7
1. Membership Eligibility	7
2. Conduct	7
3. Series Championship	8
C) Personal Safety Equipment	9
1. General	9
2. Seat Belt/Restraint System	9
3. Protective Clothing	9
4. Seats	9

5. Helmets	10
6. Fire Suppression	10
7. Other (HIGHLY RECOMMENDED)	11
D) Racing Event Procedures	12
1. Inspections	12
2. Pill Draw	12
3. Team Meeting	12
4. Hot Laps	13
5. Qualifying	13
6. Racing	14
7. Flag Rules/Official's Signals	19
8. Back Up Cars / Driver Changes	20
9. Series & Car Decals	21
E) Scoring	22
F) Payoff Procedures	23
G) Provisional	24
H) Points Breakdown	25
I) Format	26
J) Penalties, Fine Schedules & Protests	28
1. Penalties and Fine Schedules	28
2. Protests	29
K) Car Rules	31
1. Engines	31
2. Fuel	32
3. Muffler and Sound Reduction Devices	32
4. Traction Control Devices	33
5. Chassis/Frame	34
6. Weight	38
7. Body	38
8. Wings	40
9. Wheels/ Wheel Covers	43
10. Tires	43
11. Shocks	45
12. Other	46

## **A) Preface**

A High Limit Sprint Car Series event is a competitive Sprint Car racing event which is intended to be conducted and officiated in accordance with the rules herein (the 2025 High Limit Sprint Car Series Rule Book). These rules and regulations provide the guideline for all events. The rulebook may be amended from time-to-time and Bulletins or special rules may be published and/or adjusted at any particular event with the participants receiving prior notification. By participating in these events, all participants are deemed to have agreed to comply with these rules and regulations and any amendment or modifications thereof.

The rules are not intended to express or imply the warranty of safety as a result of publication of, or compliance with the rules and regulations as stated herein. The rules are intended to offer a guideline for the orderly conduct and officiating of an event. NO EXPRESSED OR IMPLIED WARRANTY OF SAFETY SHALL RESULT FROM PUBLICATIONS OF/OR COMPLIANCE WITH THESE RULES AND/OR REGULATIONS. They are intended as a guide for the conduct of the sport and are in no way a guarantee against injury or death to a participant, spectator, official, or other individual.

The High Limit Sprint Car Series Director shall be empowered to permit any appropriate amendment from any of the specifications and/or procedures herein, or impose any further restriction that, in their opinion, does not alter minimum acceptable requirements. Revisions to the rules are not intended to express or imply the warranty of safety as a result from any such deviation or restriction of the specifications, rules and/or procedures. Any interpretation of, deviation from, these rules herein, is left to the discretion of the Director and High Limit Officials and their jurisdiction and discretion is final.

Any visible equipment changes and/or performance enhancing changes to previously approved Sprint Cars and/or equipment must be approved in writing prior to introduction into competition by the High Limit Sprint Car Series Director. High Limit Officials reserve the right to immediately determine the legality and use of any equipment that has not received prior written approval for introduction into competition.

It is ultimately the obligation of each participant to ensure their conduct and equipment comply with all of the applicable rules, as they may be amended from time-to-time. The rules are in no way a guarantee against injury and/or death to participants, spectators, officials and/or others.

### **1. Definition of Terms**

**The following terms, which appear periodically throughout this 2025 High Limit Sprint Car Series Rule Book, have the following meanings:**

- a) **“A-Main”** – the feature race of an Event.
- b) **“Bulletin”** – an amendment to the Rule Book issued and published by the Series through the electronic version of the Rule Book or as otherwise issued or distributed by the Series.
- c) **“Competitor”** – A driver, car owner, crew member and/or any other person (other than a High Limit Official) who participates competitively in a High Limit Sprint Car Series sanctioned racing Event. Whenever the words Competitor, driver, car owner, mechanic, team member and/or crew member are used, unless the context indicates otherwise, the term used shall be interpreted to include any driver, car owner, crew member and/or other person assigned to or a member of the same racing team.
- d) **“Director”** – person responsible for:
  - Ensuring proper observance of the Rule Book.
  - The control of practices, qualifying and races.

- The stopping of practice or the race in accordance with the Rule Book if he/she deems it unsafe to continue and ensuring that the correct restart procedure is carried out.
  - All versions of the starting procedures.
  - Directing the use of medical cars/fast intervention vehicles.
  - Immediate approval and signature with time of provisional results (practices, qualifying, warm-ups, starting grids and races) and presentation of reports to appropriate committees.
  - Undertaking the other designated Director activities set forth in the Rule Book.
- e) **“Event”** – A High Limit Sprint Car Series sanctioned event. The event includes the main races and all ancillary activity leading up to and following the conclusion of the event, including registration/pill draw, Team Meeting, inspection (pre- and post-race), hot laps, time trials, heat races, features, and it includes events affected by inclement weather and/or postponed dates related thereto.
- f) **“High Limit Officials”** – Persons employed or contracted by the High Limit Sprint Car Series to officiate at an event, sometimes referred as “Officials.”
- g) **“High Limit Sprint Car Series”** – The trade name for the Series.
- h) **“High Limit Supervisory Official(s)”** – The employee of High Limit Sprint Car Series as designated herein. The High Limit Sprint Car Series may designate additional ‘High Limit Supervisory Officials’ in a bulletin and/or verbally from time-to-time. The High Limit Supervisory Official until further notice is as follows: [Mike Hess, High Limit Sprint Car Series Director \(217-341-0872\)](#).
- i) **“OEM”** – Original Equipment Manufacturer.
- j) **“Promoter”** – The individual, partnership, corporation, joint venture and/or other legal entity that, in connection with the Event, is designated as the “Promoter” in the executed Sanction Agreement for the Event.
- k) **“Release and Indemnity Agreement”** – a valid waiver, indemnification and release of liability agreement in form and substance satisfactory to the Series.
- l) **“Rule Book”** – The rules in this 2025 High Limit Sprint Car Series Rule Book, as they may be amended or modified from time-to-time.
- m) **“Sanction Agreement”** – The agreement between High Limit Sprint Car Series and a Promoter to promote, host and operate an Event.
- n) **“Series”** – the High Limit Sprint Car Series operated by High Limit Holdings, LLC, d/b/a High Limit Racing.
- o) **“Split Scoring”** – In the instance that there is a caution after the leader and at least one other car has crossed the scoring line, split scoring will be used: those cars that crossed the scoring line before the caution will be scored in the manner in which they crossed the scoring line. Those cars that had not yet crossed the scoring line at the time of the caution will be scored in their position in which they crossed the scoring line on the previous lap. On all laps, except the final lap, at least 2 cars must cross the scoring line to qualify for split scoring. On the final lap, only the leader must cross the scoring line for split scoring to be utilized.
- p) **“Sprint Car”** – A specified racing vehicle that fits the specifications set forth in this Rule Book.

- q) **“Start Finish Line”** – Point on the race track where the official timing and scoring loop is installed
- r) **“Team Meeting”** – High Limit Sprint Car Series Officials will conduct a Competitors meeting at each race Event.

## **2. High Limit Sprint Car Series Rules**

- a) **Effective Date** – The rules within this Rule Book are effective upon the date of publication by the High Limit Sprint Car Series for any Event, regardless of when a Competitor receives the actual notice. **“Date of Publication”** of the rules or any amendments thereto is the earliest of distribution from the High Limit Sprint Car Series and/or release to the press.
- b) **Amendment** – The High Limit Sprint Car Series rules may only be amended by publication of an amendment in an issued release/bulletin or during a Team Meeting pursuant to the authority of High Limit Officials. An amendment is effective upon the date of the publication (earliest of electronic posting, mailing, emailing or other timely distribution, or verbal announcement or distribution by the Series), regardless of when a Competitor receives the actual notice.
- c) **Interpretation and Application** – If there is a disagreement or dispute regarding the meaning or application of the rules, the interpretation and application of the High Limit Officials at the Event will prevail.
- d) **Finality of Interpretation and Application** – The interpretation and application of the High Limit Officials at the Event shall be final and non-appealable. ALL COMPETITORS AND OFFICIALS, EXPRESSLY AGREE THAT DETERMINATIONS BY HIGH LIMIT OFFICIALS AS TO THE APPLICATION AND INTERPRETATION OF THE RULES ARE NON LITIGABLE, AND THEY COVENANT THAT THEY WILL NOT INITIATE OR MAINTAIN LITIGATION OF ANY KIND AGAINST HIGH LIMIT HOLDINGS, LLC D/B/A AS THE HIGH LIMIT SPRINT CAR SERIES OR ANYONE ACTING ON BEHALF OF THE HIGH LIMIT SPRINT CAR SERIES, TO REVERSE OR MODIFY SUCH DETERMINATIONS OR TO RECOVER DAMAGES OR TO SEEK ANY OTHER KIND OF RELIEF AS A RESULT OF SUCH DETERMINATIONS, UNLESS THE OFFICIALS MADE SUCH DETERMINATIONS FOR NO PURPOSE OTHER THAN A BAD FAITH INTENT TO HARM OR CAUSE ECONOMIC LOSS TO THE COMPETITOR OR OFFICIAL. IF THE COMPETITOR OR OFFICIAL INITIATES OR MAINTAINS LITIGATION IN VIOLATION OF THE COVENANT, THAT COMPETITOR OR OFFICIAL AGREES TO REIMBURSE THE HIGH LIMIT SPRINT CAR SERIES FOR THE COSTS OF SUCH LITIGATION, INCLUDING ATTORNEY’S FEES. EACH COMPETITOR OR OFFICIAL FURTHER COVENANTS THAT IN ANY LITIGATION BROUGHT AGAINST THE HIGH LIMIT SPRINT CAR SERIES FOR ANY REASON, IF THE LITIGATION IS NOT DISMISSED PURSUANT TO THIS COVENANT THE MATTER WILL BE TRIED BEFORE A JUDGE OF COMPETENT JURISDICTION AND HEREBY WAIVES ANY RIGHT TO TRIAL BY JURY IN SUCH ACTION.
- e) **Principal Rule of Interpretation and Application** – The rules are intended to ensure that sanctioned Events are conducted in an orderly manner that is as fair as possible for all Competitors, consistent with prompt finality in competition results. On occasion, circumstances will be presented that are either unforeseen and/or otherwise extraordinary, in which strict application of the High Limit Sprint Car Series rules may not achieve this goal. In such rare circumstances, the High Limit Officials, as a practical matter, may make a determination regarding the conduct of an Event, the eligibility of a Competitor or similar matters that are not contemplated by or are inconsistent with the High Limit Sprint Car Series rules, in order to achieve this goal. From time-to-time in particular rules, Official Entry Blanks (if applicable), Bulletins and elsewhere, High Limit Sprint Car Series may use the term **“EIRI”** meaning **“Except in Rare Instances”** to indicate the likelihood that such a determination may be made.

- f) **Special Rules** – Special rules may be made by the High Limit Officials for an Event. Such special rules shall apply to the conduct of the Event if they are published or announced prior to or during the Event by means of bulletin, email, headset, newsletter, telephone, and/or pre-race Team Meeting.

## **B) Membership**

### **1. Membership Eligibility**

- a) **Full Time Competitors** – To be eligible for year end points fund monies, provisionals, and five (5) complimentary pit passes, Full Time Competitors (“**Full Time Competitors**”) must fill out a 2025 Entrant Agreement (“**Entrant Agreement**”), a Release and Indemnity Agreement, and if qualified, enter into and comply with a High Limit Double Down Agreement (“**Double Down Agreement**”), and abide by the terms in, and remain in good standing under, the Entrant Agreement and Double Down Agreement.
- b) **Competitors** – The Series does not require other Competitors to fill out a membership agreement or pay any fees to race in our Events. The only requirement is to fill out appropriate paperwork (W-9, Entrant Agreement, gambling integrity form, liability release, indemnity and waiver, insurance and other documents) as required by High Limit Officials.
- c) **Gambling and Integrity Policy** - All Competitors must comply with the Series Gambling and Integrity Policy and Owners must impose rules, requirements and restrictions on its Drivers, employees, staff, crew, contractors and licensees to require compliance with all applicable legal sports betting/gambling/wagering laws related to team, Series, and the Events and to support the integrity of Series racing. Competitors are strictly prohibited from directly or indirectly placing, soliciting or facilitation any bet or wager related in any way to any Series event (whether related to the season, races, event outcomes, individual or group statistics, performances or other components of the Series) in which Owner, team, Driver or their affiliates participate in any form or fashion, including any economic interest. Competitors will report to the Series without undue delay any attempted, requested witnessed or observed illicit or illegal gambling activity relating to the Series, any Event or team/Driver that could represent the potential for a conflict of interest, unsportsmanlike conduct, or other action(s) detrimental to Series. No Competitor may disclose confidential information for the purposes of enabling or facilitating gambling/wagering/betting activity related in any way to any Event or on- or off-track actions.
- d) **Membership Cards** – The High Limit Sprint Car Series will issue membership cards to Full Time Competitors. The car owner will receive five (5) complimentary pit passes so long as such Competitors are in good standing per the 2025 Entrant Agreement. Any misuse or those caught impersonating other team owners will have their membership revoked immediately and will forfeit all membership benefits including the points fund. If membership cards are issued and such are lost, the replacement fee for such card is \$100.
- e) **Minimum Requirements**
  - i. To be approved, secure and maintain a High Limit Sprint Car Series Membership any High Limit Sprint Car Series member, at minimum, must:
    - a. Be at least 16 years of age.
    - b. Ages 16 and 17:
      - i. A parent must also sign the Release and Indemnity Agreement.

- ii. Execute and deliver to High Limit Sprint Car Series such authorizations, releases, applications, consents, waivers, resumes and other documents as may be required from time-to-time.
- ii. Following completion of all documentation, waivers, consents, resumes, other documents and/or training modules, a driver must be approved by a High Limit Official for competition before becoming eligible to participate in any sanctioned Event.
- iii. Failure to meet any criteria may result in an indefinite suspension from High Limit Sprint Car Series Events.

## **2. Conduct**

### **a) General**

- i. All Competitors agree to act in a professional manner as determined by High Limit Officials. The professional manner includes, but is not limited to verbal representation, written representation, electronic representation, social media and/or any representation that may represent or reflect on the High Limit Sprint Car Series, the sport of Sprint Car racing and/or motorsports in general and/or any affiliates.
- ii. All Competitors will not be permitted to compete and/or participate while under the influence of any alcoholic beverages and/or illegal substances.
- iii. During an Event, any Competitor may be requested to report to the High Limit Sprint Car Series Trailer or other designated location for consultation with High Limit Officials. The request may be communicated over the one-way radio and/or verbally. Failure to comply with the request will be subject to fine and/or suspension and/or any other action deemed appropriate by High Limit Officials.
- iv. As a disciplinary action, a driver and/or race team may be parked during and/or after any High Limit Sprint Car Series Event. Parking is a directive from a High Limit Supervisory Official to cease competition and may include a directive for the Competitor(s) to not participate in an Event for a set number of laps and/or complete Event(s) and/or future Events and/or leave the premises in order to promote the orderly conduct of any High Limit Sprint Car Series Event. This directive will only be given in extraordinary circumstances by the High Limit Supervisory Official. Parking will not be construed and/or deemed to be a disqualification and/or suspension and/or other "penalty" as referenced in Section I and is not appealable.
- v. As a disciplinary action a Competitor may be placed on probation during and/or after any High Limit Sprint Car Series Event. Probation is a directive from a High Limit Supervisory Official that will be enforced beginning immediately and lasting for a time period as specified in the probation letter which will be issued and signed by the participant and the High Limit Sprint Car Series Director. Failure to acknowledge and adhere to a probation notice will result in immediate suspension from future Series Events.

## **3. Series Championship**

- a) **Championship** – The High Limit Sprint Car Series will award team owners ("**Owners**") and Sprint Car drivers ("**Drivers**") points based upon their finish in each Series race Event as set forth in Section H of

this rulebook. At the end of the Series scheduled season, the High Limit Sprint Car Series shall announce one High Limit Sprint Car Series Owners Champion and one Drivers Champion. The Owners Champion and Drivers Champion will each be awarded championship prize money as posted, based upon their cumulative point total for the Series. Tie breakers for Owners points and Drivers points will be dictated in the following order: number of wins, number of 2<sup>nd</sup> place finishes, number of 3<sup>rd</sup> place finishes and so on until the tie(s) is broken.



## **C) Personal Safety Equipment**

### **1. General**

- a) Each Competitor is solely responsible for the effectiveness and proper installation, per the manufacturer's specifications, of personal safety equipment and determining it to be acceptable for competition at every Event. Each Competitor is expected to investigate and educate themselves for continuing improvement regarding their own personal safety equipment.

### **2. Seat Belt/Restraint System**

- a) Each Sprint Car will be equipped with a minimum of an SFI 16.1 or SFI 16.5 approved restraint system, valid only until the date of the belt expiration (two years from the date of manufacture). Seat belt restraint systems shall be installed and used in accordance with manufacturer's instructions. In any type of manufacturer's installation, the fasteners must be magnetic steel unless using type of mount in which the seat belt must bolt to or wrap around the chassis. No belts to seat installation will be allowed unless pre-approved by High Limit Official. A seven- point harness is recommended.
- b) Seat belt material should not be permitted to come into contact with any sharp or metal edge, including when the material passes through the seat.

### **3. Protective Clothing**

- a) All drivers will be required to wear a fire-resistant driving uniform meeting minimum SFI 3.2A/5 specifications and display a valid SFI 3.2A/5 label.
- b) All drivers should wear SFI or FIA-rated fire-resistant accessories, including, but not limited to: head sock or helmet skirt, under garments, shoes and socks. All drivers will be required to wear fire-resistant gloves. Shoes and gloves will be required to meet minimum SFI 3.3 specifications and display a valid SFI 3.3 label.
- c) All fire-resistant clothing needs to be in good condition and will be subject to periodic inspections. Any item with holes, tears or excessive wear may not be permitted and may need to be replaced prior to competition.
- d) Drivers MUST wear all fire-resistant clothing and have their seat belts fastened at all times, including during engine heat.

### **4. Seats**

- a) All current aluminum seats must be full containment type construction and must adhere to the general design specifications of SFI 39.2 seat construction standards. Design shall include comprehensive head surround, shoulder and torso support system, energy impact foam, and removable head foam.
- b) Approved carbon fiber seats must have a current valid SFI 39.2 certification.
- c) Up fitting a current seat with bolt on kits will be permitted with a seat manufacturer produced kit and an acceptable base seat approved by the seat manufacturer. Components must include comprehensive head surround, shoulder and torso support system, and energy impact foam. It must be installed in accordance to seat manufacturer instructions. Combining components may not meet SFI 39.2 certification.

- d) Seats must be used as supplied and installed following instructions provided by the seat manufacturer.
- e) If the left side head surround is 7 inches or less when measured from the back of the headrest, then a left side head net meeting the SFI 37.1 must be installed with a quick release latch. A minimum left side head surround of 4 inches is required.
- f) The recommended driver's seats may be revised from time-to-time with additional approvals and/or other changes to the approved list.
- g) A right-side head restraint net and/or support are required. All head restraint nets should be equipped with quick release mechanisms.
- h) The approved nets may be revised from time-to-time with additional approvals and/or other changes to the approved list.

## **5. Helmets**

- a) All drivers will be required to wear a full-face helmet with a minimum safety rating of FIA 8859-2015, FIA 8860-2018, Snell SA2020, Snell EA2016, or Snell SA2015.
- b) It is strongly recommended that helmets have the Eject™ helmet removal system installed as per the manufacturer's instructions.
- c) At all times during an Event including practice, qualifying and competition (excluding starting the car for engine warm-up) it is required that drivers wear an SFI-approved head and neck restraint device/system that is properly mounted and connected per the manufacturer's instructions. The device should meet SFI 38.1 specifications and display a valid SFI 38.1 label.
- d) Arm restraints are recommended and must be connected and used as instructed by the manufacturer.

## **6. Fire Suppression**

- a) A fire suppression system that meets the SFI 17.3 specification must be installed and functional in all racecars at all times when competing with High Limit Racing. The fire suppression system must include a thermal trigger and a manual trigger, both mounted in the driver's compartment. The thermal trigger must be in the lower area of the driver's compartment forward of the seat near the area of the fuel pump. The manual trigger must be mounted where it is easily reachable by the driver while seated and belted in the seat. A minimum of one nozzle must be mounted in the lower area of the cockpit forward of the seat. The DOT approved cylinder manufactured of aluminum or steel must be securely mounted to the frame per the manufacturer's instructions and the discretion of High Limit Racing Officials. The cylinder must have a minimum capacity of 5 lbs. The system must be fully charged and display a legible and valid SFI 17.3 and manufacturer's label, easily viewable at any time by High Limit Racing Officials. Cylinders that are beyond useful certification date must be inspected, serviced and re-labeled by the manufacturer. If a nozzle is connected to the cylinder with a line, the line must be metal or metal reinforced and must be triggered at the end of the line.

## **7. Other (HIGHLY RECOMMENDED)**

- a) No sharp and/or protruding edges in and around the cockpit.
- b) Windshield screens should be a minimum thickness of 0.090 inch and should be securely fastened to the roll cage.
- c) A clearly marked electrical engine shut off switch within reach of the Driver.
- d) A clearly marked fuel shut off valve within reach of the Driver.
- e) Only SFI flame retardant seat, roll bar, knee and steering pads and/or padding should be utilized.
- f) A drive line containment system; either a steel torque ball housing made of a minimum .120 wall thickness magnetic steel attached to the firewall with steel and/or titanium bolts and/or a torque ball u-joint containment blanket is highly recommended to shield revolving parts within the cockpit.
- g) All teams should have an easily accessible 2.5-gallon FFF fire extinguisher or its equivalent at the back of the team's transporter.

## **D) Racing Event Procedures**

The rules as stated herein will cover the procedures and rules of the racing Event. Procedures and rules of the racing Event may be altered from time-to-time by High Limit Officials. Racing Event procedures and/or racing Event rules are final and non-appealable.

### **1. Inspections**

- a) All Sprint Cars entered and present at any High Limit Sprint Car Series Event that are intending to compete in the racing Event must pass pre-race inspection prior to any on-track activity and must have or obtain an inspection decal and affixed to the chassis. Pre-race inspection may take place in a specified area and/or in the regards of space directly at the team's transporter. Refusal to present the Sprint Car vehicle or preventing Officials from completing pre-race inspection will result in disqualification from that Event in addition to potential penalties, suspension and/or fines.
- b) All Sprint Cars are subject to a complete inspection at any time during the Event.
- c) Fuel will be inspected during periodic intervals utilizing a hydrometer and by chemical analysis through a fuel chemist. If a fuel sample is chemically analyzed, all winnings of that particular Sprint Car from that particular racing Event will be held until the analysis has been completed and a determination has been made by the High Limit Officials.
- d) High Limit Officials may at their discretion, impound a part/component, engine and/or any other components and/or the complete Sprint Car for competitive analysis and/or research data.

### **2. Pill Draw**

- a) All drivers and teams must draw for a position in time trial qualifying at the designated location in order to be officially entered for the Event. The drivers and/or teams are responsible for their own pill draw.
- b) All pills must be drawn prior to the posted Team Meeting time. Team Owners will have the ability to have someone draw for a time trial position on their behalf if the team is late arriving.
- c) If a Sprint Car and Driver show up after the start of the Team Meeting, but before qualifying has ended, they will be placed at the end of qualifying and be given one lap to qualify. The late Sprint Car will take its qualifying at the end of the scheduled lineup and receive only one qualifying lap. The best a late Sprint Car can qualify is 50% (lower number) + 1 of the overall number of qualifiers in a group no matter what the qualifying time of record is posted.
- d) If any Sprint Car(s) scratches after the pill draw and before the start of the Team Meeting, they will be removed from the entry list.
- e) The entry list becomes official at the start of the Team Meeting.

### **3. Team Meeting**

- a) All drivers must attend the Team Meeting. Driver and Crew Chief from each Team are required to attend each meeting. Those drivers or crew chiefs in violation of not attending the Team Meeting could face a qualifying penalty, fine, loss of driver's points, owner's points and/or suspension.

- b) The number of racecars starting each Event and the number of laps for each event will be announced at the Team Meeting.
- c) Any changes in the basic Event night program due to car count, track conditions and/or any other circumstances will be announced at the Team Meeting.
- d) There may be special event shows during the year that do not follow the standard High Limit Sprint Car Series racing formats. When such events occur, all teams will be informed of specific program and/or procedural changes for that particular event. All racing programs are subject to change and any such changes will be explained at the Team Meeting.

#### **4. Hot Laps**

- a) If wheel packing is necessary, participation is required to retain time trial position. If a Sprint Car and Driver do not wheel pack, they will be placed at the end of qualifying and be given one lap to qualify with a time no better than 50% plus 1 position of the group.
- b) Drivers must hot lap in listed group unless having trouble that is reported to a High Limit Official.
- c) Except in rare instance hot laps will be limited to one session per group.

#### **5. Qualifying**

- a) Qualifying will consist of two consecutive timed laps unless otherwise noted and when possible multiple cars at a time. Changes to the two-lap qualifying procedure will be at the discretion of the High Limit Officials.
- b) Free laps during time trials will not be given. When a car is pushed for time trials it must make its attempt beginning at the same time all other cars are making said attempt. Also, during time trials all cars must begin accelerating at the same point on the surface, meaning if a car's attempt is yellow flagged or slowed for any reason or halted due to a red flag condition, once cleared to resume the attempt, the throttle must be picked up in the same location as all other cars. If a driver feels he/she was interfered with during his qualifying attempt, he/she must notify the High Limit Officials at the scale area, and if another attempt is granted, report directly back to the time trial push off area to be the next available car to qualify and be given one additional lap. Once the car leaves the scale area no interference lap will be granted.
- c) Each car and/or team will have a two-car/group grace period to be in line for their own qualifying opportunity. If the grace period is missed the late car will take its time trial at the end of overall qualifying and receive only one qualifying lap. The best a late car can qualify is 50% (lower number) + 1 of the overall number of qualifiers in a group no matter what the qualifying time of record is posted. Once a car is pushed for qualifying, even if it doesn't start, it is considered an attempt to qualify. If the car leaves the track and goes to the pit area or returns to the qualifying push lane, it will be considered late and will only receive one qualifying lap at the end of overall qualifying and the best it can qualify is 50% (lower number) + 1 of the overall number of qualifiers in a group no matter what the qualifying time of record is posted.
- d) The cars and/or teams that are late must be in line before the last car or group receives checkered flag. Qualifying will be closed once all cars that are in line have been pushed off to begin their time trial.

e) In the event of two or more cars posting the same time in time trials, the tie breaker will be the fastest other lap time of the two consecutive recorded laps. If this does not break the tie, the tie will be broken by the qualifying order draw. In the event that one (1) lap qualifying is utilized, the tiebreaker will be the qualifying order draw. The car that with the lowest pill draw will be awarded the faster time.

f) Any car that fails post qualifying inspection (i.e. fails to report directly to the scales, too light at scales, illegal tire, wings, wheels, etc.) will lose its qualifying time of record, but will be lined up as the last car in their respective heat race.

g) All cars must report directly to the scale location after completing their time trial lap(s) and meet the minimum required weight with the Driver in the Sprint Car. Right rear tire will be marked after qualifying and must be used in the A-Main. Any legal right rear tire may be used for any preliminary event. Refusal to report directly to the scales after completing time trial lap(s) will be considered a disqualification from time trials. If time trials are interrupted due to weather or an electronic timing issue any hot lap/ heat race groups that have been completed will retain those times. Whichever group had the interruption will need to re-qualify once the weather allows or electronic issue has been fixed or timing light is set up.

## **6. Racing**

### **a) Starts**

- i. Any driver, team, and/or car, who purposely attempts to hold up the start of any race will be placed at the rear of the lineup and could be disqualified from the event, suspended and/or fined at the discretion of the High Limit Officials.
- ii. Once the allotted time (announced at the Team Meeting) allowed for being on the track or in the push off lane ready to race has expired, any late arriving car will be penalized two (2) starting positions. Any car pushed after the field has started assembling must start at the rear of the field. This rule may be adjusted from time-to-time, "EIRI", at the discretion of the High Limit Sprint Car Series Director.
- iii. All starts and restarts will take place at a consistent speed. Consistent speed will be at the discretion of High Limit Officials. Starts and restarts will take place within a designated area that will be identified at the Team Meeting. The pole setter is to set the pace for the field. The two (2) front row cars must choose their racing line entering turn three (3) and must maintain that line until the start or restart occurs. Failure to do so will result in a two (2) position penalty. The two (2) front row cars will begin the race by firing together at the chalk line in the area of turns 3 & 4. Any car out of line and/or passing before the front row has fired will bring out a caution period and will be penalized two (2) positions on the ensuing restart. However, if the offending car(s) was located in the second half of the starting grid, the race may be allowed to continue and the offending car(s) will be penalized two (2) positions from their finishing position. If the same car(s) commits a second offense it shall be disqualified from that racing event.
- iv. In the event that the race is not properly started by the two (2) front row cars, the responsible car or cars will be moved to the second row. Failure to acknowledge and comply with the "move back" signal will result in instant disqualification from the racing event.
- v. Provisional (as more fully set forth in Section H) starters for any race will not be permitted to start any race after the original start has taken place. Provisionals can enter the A-Main up until the

yellow lights go out. If the yellow or red light comes on for any reason i.e. (debris, lineup incorrect or other reasons) before the initial green flag is taken the Provisionals may still enter the A-Main.

- vi. After 3 unsuccessful attempts at an original double file start, High Limit Officials have the option to start the race in a single file formation.
- vii. The designated polesitter in each Heat Race will have lane choice for the initial start. Once the driver chooses their lane, it is final and cannot be changed, regardless of the amount of attempts it takes to start the race. Any new polesitter is afforded one opportunity to choose their lane. All Cars behind the front row will stay in the lane of the original lineup or a shuffled lineup as directed by race control.

b) **Restarts**

- i. All restarts will be single-file order of running up to the A-Main event. During the A-Main event double file restarts will occur until said A-Main event has less than ten (10) laps remaining. All races (heats, dash, preliminary main events) prior the main event will continue to be in single file order. There will not be a start-line in turn 4. The grid must remain single-file, until the race is started. The race leader sets the pace and is the control car. Once the leader starts the race it is started for the entire field.
- ii. In the A-Main event, selection of restart positions will be in effect, utilizing a choose cone on the racetrack. Once the single file order is established, drivers must not change positions until after they have chosen a lane for the restart. When instructed by a race official, drivers must choose the inside or outside lane before the cone on the front straightaway. Drivers must maintain their chosen inside or outside position until the full field order is established.
- iii. All restarts will take place with the lead lap cars moved to the front of the field. Lapped cars will pull to the inside and fall in behind the last car on the lead lap in their order of running.
- iv. A restart cone will be placed on the racetrack.
- v. If a car passes to the left of the restart cone, hits the cone, passes another car before reaching the cone, is not in a proper nose-to-tail alignment and/or is guilty of an excessive gap between cars, then that car will be penalized. When this infraction occurs, High Limit Officials may exercise their discretion and 1) call for an immediate restart and penalize the offending car(s) two positions prior to the subsequent restart or 2) not call for another restart and allow the race to continue and then penalize the offending car(s) two positions under the next yellow, red or checkered flag. If there are multiple violations by the same car(s), the respective car(s) may be disqualified from that respective race.
- vi. If the leader is unable to properly restart the race after one (1) attempt, the leader may be warned or penalized two (2) positions.

c) **Dash**

- i. When using a 2-heat format or a 3-heat format where all cars present make the A-Main, all cars must finish in the top six and on the lead lap of their qualifying heat to be eligible for the Dash.
- ii. Any car or driver that qualifies for the Dash and crashes or is otherwise injured during the Dash to the extent that they cannot start the A-Main, will be awarded with last place finishing position points and last place payout in the A-Main. No alternate starters will be allowed.

d) **B-Main**

- i. The B-Main will be cancelled if one or multiple cars scratch and the number of B-Main starters will all transfer to the A-Main. Such cars will tag the back of the A-Main by their B-Main lineup order.

e) **A-Main**

- i. Unless instructed to do otherwise, the top three (3) finishers from the A-Main must proceed directly to the scales to be weighed. Upon clearing the scales drivers must proceed directly to victory lane and participate in all victory lane activities, including, but not limited to, top 3 photos, media interviews, victory lane photos, etc. Following victory lane, the A-Main winner must report directly to the High Limit Racing designated tech area. Failure to report to the scales or tech area will result in a disqualification. Failure to report to victory lane could result in a fine and/or probation. Any extenuating circumstances will be considered.

f) **General Racing Procedures**

- i. Competitors may stop on the track during any yellow flag situation to alert an official of an unsafe condition including but not limited to driver radio not working, debris on track, driver's safety equipment malfunction, etc. and be placed back into their current running position.
- ii. Any car that does not race on the designated racing surface in order to better its position may be black flagged and penalized at the discretion of the High Limit Officials.
- iii. The maximum number of Event laps will be stated by the High Limit Sprint Car Series Race Director during the Team Meeting, but may change due to extenuating circumstances.
- iv. Cars will not be permitted to be 'pushed-off' after the lights out signal has been given or during any green flag conditions. An offending car will be automatically disqualified.
- v. Car(s) that perform a 360-degree spin and can continue without stopping, or after a caution has been called, even if contact is made with another car or obstruction, will not be charged with a caution.
- vi. If the flagman throws the caution flag without direction from the High Limit Officials and the Official deems the caution to not be necessary, all cars will retain their position from the last lap in which they were scored.
- vii. If the flagman throws any flag without direction from the High Limit Officials and the Official deems the flag to be thrown in error, the caution flag may be thrown and High Limit Officials will communicate to drivers via one way radio communication. All running cars will retain their position from the last lap in which they were scored prior to the erroneous flag being thrown and the race will be continue from the last lap scored.
- viii. At the discretion of the High Limit Official, any car that is involved in two (2) single car spins that are unaided may be disqualified from the event.
- ix. At the discretion of the High Limit Official any car that intentionally brings out a caution period will be disqualified from the event.



- x. Any car that cannot maintain a minimum race speed may be asked to leave the racing surface at the discretion of the High Limit Officials.
- xi. All races will be complete once the leader crosses the finish line at the assigned number of laps. Any race with a yellow or red flag displayed during the white flag lap will result in the race ending in a Green-White-Checkered finish unless deemed by High Limit Officials to be waived for extenuating circumstances.
- xii. If a race is red flagged and cars are sent to the pits, then any and all work, including tire changes, are permitted, except for the right rear tire during the A-Main.
- xiii. Any cars that require a push start during a yellow caution period, will be considered involved in the incident which brought out the yellow flag and that car will have to restart behind the cars on the same lap that stay on the track.
- xiv. Any cars that stop, either on the racing surface and/or in the pit/designated work area or leaves the track unauthorized during a caution period will be required to restart behind the cars on the same lap that stay on the track.
- xv. Any car or cars that are involved in a yellow or red flag situation including non-involved cars that go to the work area are required to restart behind cars on the same lap that stay on the track.
- xvi. If a yellow flag eventually results in a closed red flag situation and the determination is made to go to an open red then all cars that were considered involved in the initial accident whether they went to the work area or not will re-align at the rear of the field in their scored position on their last completed lap. Order is lead lap cars, 1 lap down cars, and multiple lap down cars.
- xvii. Any car that spins-out as the field is stopping for a red flag situation, to avoid the incident at the discretion of a High Limit Official, will retain their running position as long as such car does not go to the designated work area.
- xviii. A spin or stoppage that requires a car to be restarted during a yellow flag slowdown period is considered as being involved and will result in that car or cars restarting behind the cars on the same lap that stay on the track.
- xix. Any car that stops because of a blocked track, at the discretion of a High Limit Official, will not be considered involved in the red or yellow flag incident.
- xx. Any car that is stopped for consultation during a caution period will retain its position only if the High Limit Officials deem the car 'clear' and permit it to return directly to competition without adjustment.
- xxi. Any car that requires a push-off at any time during an event must have a rear bumper [securely](#) in place.
- xxii. If it is determined in any race, after the original start, that any Competitor deliberately initiates a caution period, by any means, that Competitor will not be permitted to restart that race. The determination of what constitutes deliberately instituting a caution period will be at the judgment of the High Limit Officials.

- xxiii. Adding fuel, whether on the track or in the work area, will not be permitted when yellow flag and/or closed red flag conditions exist. Violators are subject to disqualification and/or fine and/or suspension and/or any other action deemed appropriate by High Limit Officials.
- xxiv. In the event that a race car is inadvertently or purposely hit by a push truck, pace vehicle, or another race car during push-off, or under yellow flag conditions or other non-racing activity and such incident is witnessed by a High Limit Official, then repairs can be made to the contacted vehicle and that car will maintain its running position. The maximum time period allotted for such repairs is six (6) minutes. If repairs can be completed within this time period, then the car will be scored where it was running or scheduled to start when such accident took place. In the event that the car may not complete the race, the car will be scored last on the lap in which that car has completed.
- xxv. For any cautions after the initial green flag has been displayed and without completing a lap, the line-up would be adjusted as follows: any cars not involved in the caution will be crisscrossed.
- xxvi. Designated work area time is 1 minute for all preliminary events or cars that have a flat tire only. Then, 2 minutes for A-Main for any work to be performed. The work area is always open; however, time will not be given during the Dash, if a car is one or more laps down, and last half of any events. If a flat tire occurs after push off before initial green in the A-Main, 1 minute will be given in the work area. Work area guaranteed time is limited to one occasion during any event. Any additional work area trips will not have guaranteed time. No changing of any tire or wheel unless flat or damaged and approved by an Official. No adding fuel in the work area unless it's an open red. Any cars going to the work area and re-entering the race together will be positioned in the order of their last scored lap at the rear of the field behind cars that are on the same lap as they are. If a restart green flag is displayed and followed by a yellow or red flag before a lap is scored, then any car(s) that remained in the work area can re-enter the race but will be positioned behind any same lap car that took the aforementioned restart green flag. Any car(s) remaining in the work area after a restart lap has been scored, may NOT re-enter that race.
- xxvii. Late arriving driver and car combinations will be allowed to race under the following guidelines:
- If car and driver arrive after time trials are completed, they will be placed at the tail of the heat race that is next to have a car added to it.
  - If car and driver arrive after the first heat race has started, they can be placed at the tail of either the next event they are ready for. Cars will need to start those races in order to get paid.
  - If car or driver arrive after the first heat race has started and there is no B-Main, car and driver would need to start the A-Main in order to get paid. If car and driver do not start the A-Main, they will not be paid.
- xxviii. If any car which has been confirmed "scratched" to a High Limit Official by a designated team representative, wishes to re-enter, the car must start on the tail of any event it is qualified for. If any cars scratch or elect to go to tail prior to a race line-up being posted on the line-up board, remaining cars will be crisscrossed forward in the line-up.
- xxix. All work on the racecar, once any race has been staged, must be completed in the designated work area unless informed otherwise. Any participants who work on the car other than in the designated work area are subject to disqualification and/or fine and/or suspension and/or any other action deemed appropriate by High Limit Officials.
- xxx. All cars will receive only one (1) 'push-off' per race. If a car needs more than one (1) 'push-off', except for safety reasons, during any race, that car will be placed at the tail end of cars on the same

lap. A 'push off' is considered completed only when the pushed car has started and pulled away from the push vehicle.

- xxxi. Competitors will not be permitted to tamper with track racing surface. Any participants who tamper with the track racing surface are subject to disqualification and/or fine and/or suspension and/or any other action deemed appropriate by High Limit Officials.
- xxxii. The addition of bolt-on weight during any yellow and/or red flag condition will not be permitted.
- xxxiii. The High Limit Sprint Car Series scales will be available and open to scale cars prior to hot laps at every event.
- xxxiv. All cars are subject to being weighed at any time during any event.
- xxxv. If a car is found to be light after any race, it will be scored last for the event but retains its times of record from time trials. Any car that is found to be light after the A-Main will be scored last, awarded last place points, and receive last place money.
- xxxvi. Each car will have (3) three attempts to meet the minimum required weight.
- xxxvii. When instructed to do so by the High Limit Officials, cars must proceed immediately to the scale area. Competitors will not be permitted in the area and/or to approach the car prior to reaching the designated area until it is weighed and released by a High Limit Official.
- xxxviii. Except for extenuating circumstances drivers must remain seated in their typical racing position in the vehicle during the weighing process unless released by High Limit Officials. If a driver leaves the car without prior consent it could result in a disqualification from the event in which the car is competing in.

## **7. Flag Rules/Official's Signals**

- a) **Green Flag:**
  - i. When the starter displays the green flag, the track is open for racing.
  - ii. The green flag signifies the start or restart of any race and/or time trial run.
- b) **Yellow Flag:**
  - i. When the yellow flag is displayed and/or the yellow caution lights are illuminated, this signifies a caution period.
  - ii. When the yellow flag is displayed and/or caution lights illuminated no passing is permitted unless instructed to do so by High Limit Officials.
- c) **Red Flag:**
  - i. When the red flag is displayed all cars on the racing surface and in the pit areas must come to a complete stop in a controlled manner, while not stopping and/or driving through the area of the incident.
  - ii. During any red flag situation all drivers, unless involved in the incident, must remain in their car unless otherwise instructed by High Limit Officials.

- iii. At the discretion of the High Limit Officials a work area may be designated on the racing surface. All cars will be pushed to the designated work area on the racing surface before work begins.
  - iv. CLOSED RED: The track will be closed. Competitors will not be permitted on the race track and/or to their race cars.
  - v. OPEN RED: The High Limit Sprint Car Series Director will determine when the track is open. When the High Limit Sprint Car Series Director determines that the racing may resume; an air horn designating the start of a 2-minute work period will be sounded. Any repairs and/or adjustments, except changing a tire or wheel, can be made to the race car. At one minute remaining, the air horn will be sounded twice. At the end of the 2-minute period the horn will be sounded, officially ending the work period. Crews must be clear of their car when the 2-minute period has expired or be penalized 2 running positions. Last row cars violating this procedure will be penalized 2 positions from their finishing position. Any car still being worked on once the field has started assembling will be disqualified and not allowed to re-enter the race.
- d) **Black Flag:**
    - i. When a black flag is displayed for the sprint car (mechanical, tire, wing, etc.), the driver that the flag is being displayed toward must bring their car to the designated work area immediately for consultation. The car will not be scored from the point that the black flag has been displayed. If after the car is inspected and it is able to return to competition, the car may only return to the track during a caution and/or red flag period.
    - ii. When a black flag is displayed for the detrimental actions of a driver, the driver that the flag is being displayed toward must bring their car to the pits and both the driver and car are subject to Event disqualification.
  - e) **White Flag:**
    - i. If the white flag is displayed and the leader of the race crosses the scoring loop, it signifies that the leader of the race and/or the car that is qualifying has started the last lap of that event.
  - f) **Checkered Flag:**
    - i. When the leader of the race crosses the scoring loop under green flag conditions on the final lap, it signifies the completion of the race and/or the car that is qualifying has completed qualifying. Split scoring will be utilized, per the definition above, if a caution is called after the leader has crossed the scoring loop on the final lap.
  - g) **Official Signals:**
    - i. All drivers must obey signals, communications, and/or any other Official's communications that assist in the direction and facilitation of creating proper lineups and/or the process of completing the event.

## **8. Back Up Cars / Driver Changes**

- a) Any substitute driver may or may not be a driver that has not already competed in the respective event. That driver would not gain driver points but owner would be eligible for owner points.
- b) A backup car may be introduced at any time between qualifying and the start of the A-Main due to the original car not operating properly and/or from extensive damage. Such determination will be at the sole discretion of the High Limit Officials.

- c) Any such change will result in the driver starting at the rear of the next race in which the car has qualified for.
- d) If a driver changes cars after practice, that driver will remain in his drawn position for time trial qualifying and will be positioned in subsequent races accordingly. If a backup car is introduced, the car must pass pre-race technical inspection prior to any competition. A backup car may be obtained from any source and does not have to be part of a team's original equipment. Once a car has been withdrawn by a team from an event, that car will not be allowed to be resubmitted to competition during that event.
- e) Officials reserve the right to waive certain aspects of the backup car rules when an event consists of 2 or more A-Main events.
- f) If a car is entered into an event, it may only be used as a backup for another team if the car has completed its racing events without successfully qualifying for the next respective race. For example, if a car did not transfer to the B-Main through the C-Main, that car would then be eligible to be used as a backup car for another team. If a team voluntarily withdraws its car from an event without completing the racing events in which the car qualified for, that car is not eligible to be used as a backup for another team.
- g) For events in which the A-Main is rescheduled for another date, all driver changes must be pre-approved by High Limit Officials. The starting spots for such A-Mains are owned by the team owner. However, the team owner cannot pass his starting spot to another team owner regardless of who the driver is.

## **9. Series & Car Decals**

- a) The High Limit Sprint Car Series decal and designated sponsor and contingency decals must be displayed prominently without modifications made to each respective decal on both sides of the outside top wing. Teams may place decals on any portion of both sides of the outside top wing; however, the bottom 8 inches of the outside top wing is the recommended and preferred area.
- b) The High Limit Officials may refuse to allow a participant to compete in an event if it is determined at their discretion that any advertising and/or sponsorship or similar agreement is detrimental to the sport, the Series, the event promoter, including the image of the sport.
- c) Failure to comply with any of the above rules may result in a loss of Point Fund monies, purse monies and/or any other penalty as deemed necessary by High Limit Officials.

## **E) Scoring**

- a) Split Scoring will be utilized for all races within the Event.
- b) All races are scored at the designated finish line. Electronic scoring line may not always be the same location as the finish line.
- c) The official starting lineup will be posted by the High Limit Officials after the completion of all qualifying events.
- d) Restart lineups will be derived from the Series scorer using the electronic scoring system.
- e) All cars that were scored under green flag conditions will hold that scored position with all other cars lining up according to their last completed green flag scored lap. This partial lap will count toward the Event's total number of laps.
- f) A lap will not be scored on the original start and/or any restart unless all cars complete the lap by passing through the start/finish line, except for the cars involved in the incident.
- g) On all yellow & red flag stoppages, lapped cars will be placed at the tail.
- h) Any car deemed to have caused an intentional yellow because of a bad start, restart, becoming lapped, or in danger of being lapped, may be disqualified.

## **F) Payoff Procedures**

- a) All paid purses, appearance money and/or other awards and/or funds as outlined in the promoter's contract shall be paid to the car owner and/or designated owner's representative at the High Limit Sprint Car Series trailer following the conclusion of the last event. All such payments will be made only when transponders are returned.
- b) A race is considered complete as determined by High Limit Racing Officials. Purse will be paid at this point.
- c) If a promoter wants to pay all qualified cars A-Main start money; the B-Main will still be run and the car or cars that do not transfer thru the B-Main will receive A-Main start money, but will not start the A-Main and will only receive show up points. If such car or cars have a provisional available, such provisional may be used to start the A-Main.

## **G) Provisional**

- a) Provisionals are permitted in the A-Main event; the car(s) will earn full points.
- b) Each Double Down member in good standing will receive three (3) provisional before the start of the points season. Good standing shall mean such members that have attended 100% of the High Limit Events to the date when a provisional is needed and have not participated in unsanctioned High Limit Events on the same dates of all High Limit sanctioned Events. Mid-week Series members will be allowed one (1) provisional per amount of mid-week races. Double Down members will be granted one (1) extra provisional for mid-week use.
- c) Medical provisionals will be granted to a Driver that has an accident with injuries needing some extra days to heal. These provisionals will be granted in a 10-day period and that Driver and or car will receive points for their average finishing position +5 positions. The driver must have gone to a reputable doctor in the 10-day period approved by High Limit Officials. If the Owner would like to race with a different driver during this time, they can but will not receive the guaranteed points. The Owner will receive points for their finishing position on that night. After 10 days, the Driver may be granted one extension if needed and approved by High Limit Officials. The first two weekends will not be eligible for Medical provisionals in 2025. After those weekends, a finishing position average can be calculated. The two weekends will apply to new teams in following years. Returning cars will receive their average finish from the year prior if needed in the first two weekends.
- d) Any Team using a provisional shall forfeit the minimum start money paid for the A-Main. Any position attained that pays greater than the start money will only be paid as advertised less the start money amount.
- e) All Teams wanting to take a provisional must have attempted to compete in at least one preliminary event leading up to the A-Main. Preliminary events shall include qualifying, heat races and D/C/B-Mains.
- f) Provisionals tag the rear of the A-Main.
- g) Unlimited High Limit Sprint Car Series provisionals will be permitted based on eligibility.
- h) The following guidelines will be used for determining provisional order:
  - i. Beginning on the second scheduled night of point racing, the provisional order will be established by combining the Car Owner and Driver lists into one, numerically sequenced, list. If a team consists of an Owner and a different Driver, then that team uses whichever has the highest point position. Owner Points will take precedent if a tie exists between any Owner and Driver. Other ties will be broken first by A-Main Feature wins, then top 5 finishes, then top 10 finishes, and finally by qualifying position.
  - ii. If at any time during the racing season a Team separates and both the Owner and Driver retain their Provisional status then both the Owner and Driver will be eligible for any unused Provisionals the Team had when the separation occurred.



## H) Points Breakdown

The following table presents the points breakdown versus finishing order for the A-Main events.

1. 77	5. 63	9. 55	13. 47	17. 39	21. 31
2. 72	6. 61	10. 53	14. 45	18. 37	22. 29
3. 68	7. 59	11. 51	15. 43	19. 35	23. 27
4. 65	8. 57	12. 49	16. 41	20. 33	24. 25

Show-up points: 20 (all cars that do not qualify for the A-Main)

- a) Each High Limit Sprint Car Sprint Car Series sanctioned event(s), regardless of the purse or format, will be full point awarding events, unless High Limit Officials announce, prior to a scheduled event, that said event will not award points.
- b) Show up points will be awarded when cars are on the track and/or when motors are fired at the direction of the High Limit Officials.
- c) Tiebreakers for year end points fund will be the number of A-Main wins, followed by 2nd place finishes and so on, until all ties are broken.
- d) The High Limit Sprint Car Series has the right, but not the obligation, for all co-sanctioned race(s) to award High Limit Sprint Car Series points as follows: the highest finishing driver that is a Full Time Competitor will receive first (1<sup>st</sup>) place points, regardless of the actual race finishing position and/or what Main Event the highest finishing Full Time Competitor competes in.
- e) If a team changes drivers during an Event, the team Owner can use any approved substitute Driver that has not competed in such respective Event and team Owner will receive full Owner points. The Driver that qualified the Sprint Car will receive show up points. The substitute Driver will not receive any Driver points.
- f) To be eligible for Rookie of the Year honors with High Limit Racing, the Driver must not have competed in more than 60% of any National 410-Winged Sprint Car Series in the past. Additionally, once a Driver accumulates five (5) High Limit Racing A-Main event victories, they will no longer be eligible.

## **I) Format**

### **2 Heat Format – 20 Cars or Less**

- a) Everybody qualifies within a single flight to lineup 2 Heat Races (8-10 Laps)
- b) Quickest car in each Heat is inverted to 4th with all others starting straight up
- c) All transfer to A-Main
- d) Top 2 + fastest qualifier in top 5 transfer to Dash redraw. If winner is fastest transfer, he is guaranteed a dash front row starting position and the 3rd place car from that heat will be included in the dash. Those starting positions that those winners occupy in the front of the dash will be taken out of the available starting positions to draw for during the dash draw.
- e) All other positions line straight up from heat finishes in A-Main

### **3 Heat Format – 31 Cars or Less**

- a) Everybody qualifies within a single flight to lineup 3 Heat Races (8-10 Laps)
- b) Quickest car in each Heat is inverted to 4th with all others starting straight up
- c) 1st-6th transfer with all others to B-Main
- d) Winner + fastest transfer to Dash redraw. If winner is fastest transfer, he is guaranteed a top 3 starting position in the dash and the 2nd place car from that heat will be included in the dash. Those starting positions that these winners occupy in the front of the dash will be taken out of the available starting positions to draw for during the dash draw
- e) A-Main is lined up by finishing positions 2-6 from heat races lining straight up behind dash cars
- f) B-Main is lined up by heat finishing positions 7+ straight up with the 2 fastest cars that didn't transfer occupying the front row of the B-Main. B-Main transfers line straight up in the A-Main from B-main finishing positions behind A-main cars

### **32 Cars or More**

- a) Split Qualifying begins at 32 cars and cars will be seeded into 2 groups. We will draw to see which group is A or B.
- b) Quickest car in each Heat is inverted to 4th with all others starting straight up
- c) 1st-5th transfer with all others to B-Main, C-Main, D-Main if needed
- d) Winner + fastest transfer to Dash redraw. If winner is fastest transfer, he is guaranteed a top 4 starting position in the dash.
- e) A-Main is lined up with cars finishing in positions 2-5 from heat races.

- f) B-Main is lined up by heat finishing positions 6+ straight up with the 2 fastest cars that didn't transfer occupying the front row of the B-Main. B-Main transfers line up in the A-Main straight up from B-main finishing positions behind A-main cars
- g) C-Main and D-Main may be added depending on car count. C and D Mains transfer 2 to back of next main
- h) B, C, and D mains may change in car count depending on track size and/or conditions
- i) 1 or 2 NQ races may be added after 48 cars are present. Top 4 or 8 in the NQ(s) transfer to the back of subsequent heat races. 1 to 1, 2 to 2, 5 to 1, 6 to 2, etc.
- j) In multi-day shows at the same track, with no pre-established format, the top three or four (pending on car count) finishers in the A Main from the first night will lock-in to the top Qualifying positions on the second night. They will start 4th in their respective heat races.

Both the driver and team must remain the same to be eligible for the lock-in position on the second night. There are no substitutions.

If a driver and/or team does not return for the second night, the lock-in position will transfer to the next highest finisher from the first night.

### **Lap Counts**

- a) Heats – 8-10 laps
- b) Dash – 7 laps
- c) D-Main – 8 laps
- d) C-Main – 10 Laps
- e) B-Main – 12 Laps
- f) A-Main – 25-30 laps on big tracks; 35 laps on mid-size tracks; 40 laps on small tracks.

## **J) Penalties, Fine Schedules & Protests**

The High Limit Sprint Car Series conducts itself as one of the top Sprint Car racing series in the United States and expects its Competitors to conduct themselves in a professional manner at all times during any event and/or when representing the series. The team Owners are solely responsible for the conduct of their drivers and/or team members and/or anyone connected to or affiliated with that owner's team. All fines that are listed in Sub-section I are in regard to the initial penalty. Multiple infractions of the same type will increase the severity of the penalty.

### **1. Penalties and Fine Schedules**

- a) All fines may be collected from prize money on the day of the infraction or purse winnings may be withheld if a post-race inspection requires additional time to inspect the car, including, but not limited to sending tire samples to a laboratory for independent testing. If the Competitor has not won appropriate money, the fine must be paid in full before the car and/or driver participates in another High Limit Sprint Car Series sanctioned Event. Team Owners are ultimately responsible for paying fines on behalf of all Competitors on their respective team.
- b) Any Competitor that attempts to and/or does physically abuse any event Official, including pushing, punching, touching, grabbing and/or grabbing the Official's equipment, etc., will be subject to disqualification and/or fine and/or suspension and/or legal action and/or any other action deemed appropriate by High Limit Officials. Maximum = \$5,000.
- c) Any Competitor that verbally abuses any Event Official will be subject to disqualification and/or fine and/or suspension and/or legal action and/or any other action deemed appropriate by High Limit Officials. Maximum = \$500.
- d) Any Competitor that attempts to push their racecar off from the wrong area and/or does not stop in the designated area as to cause undue confusion and/or delay will be subject to fine and/or suspension and/or any other action deemed appropriate by High Limit Officials. Maximum = \$500.
- e) Any Competitor who fails to stop for and/or allow post-race inspection will be subject to disqualification and/or fine and/or suspension and/or any other action deemed appropriate by High Limit Officials. Maximum = \$500.
- f) Any Competitor that attempts to and/or passes the pace vehicle (unless instructed to do so) will be subject to the loss of two (2) positions and/or disqualification and/or fine and/or suspension and/or any other action deemed appropriate by High Limit Officials. Maximum = \$100.
- g) Any Competitor that attempts to drive roughly and/or bumps another Competitor unnecessarily will be subject to disqualification and/or fine and/or suspension and/or any other action deemed appropriate by High Limit Officials. Maximum = \$5,000.
- h) Any Competitor that attempts to use illegal fuel will be subject to disqualification and/or fine and/or suspension and/or loss of points and/or any other action deemed appropriate by High Limit Officials. Maximum = \$5,000.
- i) Any Competitor that attempts and/or is found to be using tires that are found to be illegal in any manner will be subject to disqualification and/or fine and/or suspension and/or loss of points and/or any other action deemed appropriate by High Limit Officials. The minimum penalty will be as follows;

disqualification from the Event, a fine of 1,000 Owner and Driver championship points, loss of all earned purse and/or award money from the Event, a fine equal to and/or more than the purse money awarded for the Event, and/or a minimum suspension that includes all Events remaining in the High Limit Sprint Car Series racing schedule for that season.

- j) Any Competitor that attempts to or uses an illegal engine will be subject to disqualification and/or fine, and/or loss of points, and/or suspension that includes all Events remaining in the High Limit Sprint Car Series racing schedule for that season, and/or any other action deemed appropriate by High Limit Officials. Maximum = \$5,000.
- k) Any Competitor that fails to quickly stop for a red flag or drives through the incident area will be subject to a loss of two (2) positions penalty and/or disqualification and/or fine and/or suspension and/or loss of points and/or any other action deemed appropriate by High Limit Officials. Maximum fine: \$500.
- l) Any Competitor that goes into another Competitor's pit area or to another Competitor's car and becomes involved in any type of altercation will be subject to disqualification and/or fine and/or suspension and/or loss of points and/or any other action deemed appropriate by High Limit Officials. Maximum = \$5,000.
- m) Any Competitor involved in an altercation that results in physical contact will be subject to disqualification and/or fine and/or suspension and/or loss of points and/or any other action deemed appropriate by High Limit Officials. Maximum = \$5,000.
- n) Any Competitor who drives a racecar in an area that is closed to racecar traffic or drives through the pit area at excessive speed with either a racecar, scooter or 4-wheeler will be subject to disqualification and/or fine and/or suspension and/or loss of points and/or any other action deemed appropriate by High Limit Officials. Maximum = \$500.
- o) Any Competitor who goes out onto the racing surface or any other controlled area including the infield when closed to Competitors without permission under a controlled period will be subject to disqualification and/or fine and/or suspension and/or loss of points and/or any other action deemed appropriate by High Limit Officials. Maximum = \$500.
- p) Any Competitor who ignores a flag or Official signal will be subject to disqualification and/or fine and/or suspension and/or loss of points and/or any other action deemed appropriate by High Limit Officials. Maximum = \$500.
- q) Any Competitor who is found to be in violation of the substance abuse policy at any event will be subject to disqualification and/or fine and/or suspension and/or loss of points and/or any other action deemed appropriate by High Limit Officials. Maximum = \$10,000.
- r) Any Competitor who exits their car onto any area where other cars are still moving will be subject to disqualification and/or fine and/or suspension and/or loss of points and/or any other action deemed appropriate by High Limit Officials. Maximum= \$500.
- s) Any Competitor that publicly criticizes the High Limit Sprint Car Series via social media, including re-tweets (Twitter, Facebook, etc.) or thru quotes given to news reporters will be subject to a fine. Maximum = \$500.

## **2. Protests**

- a) All protests must be turned into the High Limit Sprint Car Series Director within five (5) minutes of the posting of the official finish.
- b) The protest filing fee and protesting fee must be paid at the time of the protest.
- c) Only the car owner, the driver and/or the designated team representative of the car owner may turn in an official protest.
- d) Any refusal of inspection and/or non-compliance during an official protest will result in the disqualification of the protested car and the prescribed penalties.
- e) If the car protested is found legal, the protesting fees will be released to the protested team less the protest filing fee.
- f) If the car protested is found to be illegal, the protesting fees will be returned to the team filing the protest less the protest filing fee.
- g) Any altercation relating to the incident with Officials and/or any other racing participants by the team filing the protest will nullify the objection.
- h) PROTESTING FEES: (Figures in parentheses are protest filing fees): Motor tear down involving heads off and cylinders inspected; \$750 (\$75): This allows the inspector to inspect block only. Weight will be \$750 (\$75) and the protest must be made prior to the protested car crossing the scale. P&G Tests, fuel test including chemical analysis and all other technical protests; \$500 (\$50).
- i) TIRE PROTESTS: Tire protests may involve one and/or both rear drive tires. The protest fee will be \$750 per tire and a protest filing fee of \$75. The protest will require the submission of the protested tire(s) by the car Owner, Driver and/or designated representative which has filed the protest. The tire(s) involved in the protest will be shipped, processed and chemically analyzed at a facility designated by High Limit Sprint Car Series Director and/or the tire manufacturer. The determination of the facility will be final and non-appealable.
- j) The High Limit Officials reserve the right to ask for a legality test at any time (sealed motor and/or otherwise). If through testing procedures a car is found to be illegal, responsibility for proving otherwise is solely with the team that was checked. There will be no exchange of money for tests asked for by Officials when a formal protest is not turned in.
- k) The High Limit Officials reserve the right to accept or deny any protest based on their sole discretion. 'Grudge' protests and/or any protest that are 'not in the spirit of good standing' will be denied.

## **K) Car Rules**

ANY SPRINT CAR, TEAM AND/OR DRIVER THAT DOES NOT MEET THESE SPECIFICATIONS AND/OR EQUIPMENT REQUIREMENTS WILL BE SUBJECT TO PENALTIES AS DETERMINED BY THE HIGH LIMIT OFFICIALS.

### **1. Engines**

- a) Only small block V-8 engines with the cam in the block and a maximum of 410.00 cubic inches of displacement (tolerance + 0.000) will be permitted. The formula  $6.2832 \times \text{bore}^2 \times \text{stroke}$  will apply. Big block engines will not be permitted.
- b) The engine must be mounted in-line with the driver and the drive-line must pass beneath the driver on center through the driver compartment. Offset engines and/or offsetting the position of the engine will not be permitted.
- c) The engine block and cylinder heads must be machined from cast aluminum. Billet machined blocks and/or cylinder heads will not be permitted.
- d) Engines with the magneto and/or distributor in a forward mounted and/or front mounted position will be allowed but must be approved prior to competition. Engines with the magneto and/or distributor mounted in the stock OEM production position for the block and/or engine must be approved prior to competition.
- e) Approved Front Drive Magneto System: Moroso 60205 & 60206.
- f) Only normally aspirated engines will be permitted. Turbo chargers, super chargers and/or forced induction of any type and/or description will not be permitted.
- g) The maximum engine cylinder bore size shall be 4.165 inches.
- h) All engine cylinder sleeves (inserts) must be machined from an iron and/or steel alloy.
- i) Titanium crankshafts, connecting rods and/or rod caps will not be permitted.
- j) Only two (2) valves and one (1) spark plug will be permitted per cylinder.
- k) Cylinder heads must retain a traditional valve pattern. Rotation of the valves will not be permitted. Canted or splayed valve cylinder heads must be approved prior to introduction into competition.
- l) Only steel connecting rods with a maximum length of 6.000 inches will be permitted.
- m) All oil pans must have an inspection plug. The inspection plug must be a #12AN fitting or 1.00 inch pipe plug.
- n) In the event that an engine does not have an inspection plug the oil pan must be removed for inspection prior to competition.
- o) Only throttle plate (butterfly) and shaft throttle body styles with round circular bores will be permitted. The maximum throttle bore as measured at the throttle plate (butterfly) may not exceed 3.000 inches in diameter. Slide plate, rotary cylinder, and/or other styles will not be permitted for competition. Carbon

fiber manifolds and/or any other injection type pieces manufactured from carbon fiber will not be permitted.

- p) A maximum of 16 fuel nozzles, utilizing two (2) per cylinder will be permitted. One (1) nozzle must be placed in the cylinder head and one nozzle must be placed in the injector.
- q) A minimum of two (2) throttle return springs must be used to mechanically return the throttle to a fully closed position.
- r) Only magneto-type ignitions will be permitted. A single (1) crank-trigger type system will be permitted as a backup ignition system. One (1) single switch that alternates the current between the magneto and the crank trigger only may be mounted to the dashboard within the driver's reach. Only 2-way, on-off type switches will be permitted. Multiple coil-pack ignitions will not be permitted.
- s) Steel and stainless steel headers will be permitted. Titanium headers will not be permitted.
- t) New engine components and/or new engine configurations must be submitted and approved by the High Limit Sprint Car Series Director.
- u) If an engine is inspected and it measures over 410.00 cubic inches, the driver and the car will be disqualified. All earned points and money will be forfeited for that event and the driver, car and owner will be suspended for all Events remaining in the High Limit Sprint Car Series racing schedule for that season. NOTE: The engine may be checked at any time during an event or torn down after the event at the discretion of High Limit Officials. If a High Limit Official finds the motor to be illegal, the Competitor will be given the opportunity to remove the cylinder head for clarification purposes. There will be a one-hour time limit set for this process following the conclusion of the A-Main.

## **2. Fuel**

- a) Fuel additives, including but not limited to nitro, nitro methane and/or nitrous oxide injection will not be permitted. Pure methanol and/or other approved fuels will be permitted. Fuel samples may be taken from time-to-time for inspection and analysis.
- b) The same fuel cell/tank must be used in the same car for the entire race program. The fuel cell/tank may be changed at the discretion of the High Limit Sprint Car Series Director if the cell/tank has been contaminated and/or physically damaged for any unforeseen reason. If fuel cell is allowed to be changed, the same size or smaller fuel tank must be used. Fuel cells with larger capacity than the one being replaced will not be permitted unless approved by a High Limit Racing Official.
- c) A fuel cell with bladder and foam will be the only type fuel cells permitted. The fuel cell must be of one piece construction of cross-link polyethylene plastic. Alterations and modifications will not be permitted.
- d) All teams racing with the High Limit Sprint Car Series will be encouraged to run a 33-gallon fuel tank and bladder. At all High Limit Sprint Car Series Events, 33 gallons of fuel will be considered as part of the formula utilized when determining the total time prior to refueling in any specified and/or announced event.



### **3. Muffler and Sound Reduction Devices**

- a) Only the Schoenfeld (part # 14272735-78) muffler will be permitted. The specified muffler must remain unaltered from the manufacturer and are mandatory at all tracks that require mufflers.
- b) All mufflers must be securely mounted. Mufflers that are mounted with pop rivets and/or sheet metal screws will not be permitted.
- c) Any muffler changes after the car has been through inspection will not be permitted. Mufflers used in qualifying must be used through the entire racing program. The only changes that will be permitted will be at the discretion of the High Limit Sprint Car Series Director. Physical damage from a crash and/or other incident will permit a change, but then the car must be inspected again.
- d) The mufflers must remain attached to the headers at all times. All muffler and header components must remain intact and operating. If the muffler becomes disconnected from the header and/or fails to operate it could result in disqualification from that race. If the muffler and/or header is damaged from and/or altered from track debris, a crash and/or a physical defect and/or no muffler components were lost and/or missing the penalty will be at the discretion of the High Limit Officials.
- e) Any muffler and/or header that has been altered in an attempt to gain a competitive advantage will not be permitted into competition and could result in disqualification.
- f) All muffler rules and/or decibel (DBA) constraints are subject to state and local regulations. In addition, monitoring by High Limit Officials will aid in enforcing the rules and regulations of those agencies.
- g) When qualifying, any car determined to be in excess of the decibel limit(s) set by either the track and/or any local agency, will receive only one (1) lap of qualifying at the end of time trials. The best the car can qualify is 50% (lower number) + 1 of the overall number of qualifiers in a group no matter what the qualifying time of record is posted. If the car pulls off and no time is recorded, the car will be permitted one (1) lap at the end of time trials. If during that attempt the car remains louder than the limit it will result in an automatic disqualification.
- h) Any header that is not straight out the back of the car with or without a muffler must be welded where the bend connects to header and to the muffler.
- i) West Coast Muffler Requirements:
  - i. Silver Dollar and Placerville: Competitors must use the Flowmaster 53545-10 or SpinTech 1545 big box muffler. If using the Flowmaster muffler, turn downs are highly recommended but not required.
  - ii. Thunderbowl, Kings, Douglas County and Skagit: Competitors must run one of the following: Schoenfeld 14272735-78, Flowmaster 53545-10, SpinTech 1545 big box or Extreme mufflers. If using the Flowmaster muffler, turn downs are highly recommended but not required.
  - iii. DBA requirements must be met and noise requirements will be enforced. Max DBA is 95, measured at 100 feet.

#### **4. Traction Control Devices**

- a) Traction control devices of any type are not permitted at any time, during any event.
- b) Any team found with a traction control device in pre and/or post-race inspection shall be disqualified from that event. Additional penalties, including indefinite suspension and/or fines, and/or any penalty deemed appropriate by the High Limit Sprint Car Series Director may be issued.
- c) From time-to-time random inspections will occur and various components may be impounded for further analysis and inspection including, but not limited to ignition systems, ignition boxes, wiring looms and/or tachometers.
- d) The Xtreme 30 sparkbox version #2 both long & short is LEGAL. The Xtreme 30 sparkbox version #3 both long & short is ILLEGAL. Check with manufacturer for correct and legal application.

#### **5. Chassis/Frame**

- a) All chassis/frames built during and/or after the 2005 season should have a manufacturer's serial number and identification plate visible and welded on the left front side of the roll cage upright.
- b) Roadster type chassis will not be permitted. Slip-tubing is not allowed in the chassis construction. This includes safety bars. Any existing slip-tubing must be replaced or welded. Clamped or bolted slip tube joint will no longer be allowed.
- c) The chassis must have a minimum of six (6) mounting points for securely mounting any manufacturer's seat per the seat and chassis manufacturer's specifications.
- d) Drag links must be made of 4130 steel a minimum of one (1) inch in diameter and a minimum material thickness of .058 inches. Drag links, Tie Rods and Left Front Radius Rods must be 4130 steel with magnetic steel rod ends. Swedging of the tubing will not be permitted. The drag links must be tethered to the frame with a minimum of one (1) inch nylon webbing and meet the approval of the High Limit Officials.
- e) Hollow and/or drilled bolts, fasteners, and/or heim joints (rod ends) will not be permitted.
- f) Only front axles made of magnetic steel will be permitted. Approved axle dimensions are:  
2-1/4" x 0.120"  
2-3/8" x 0.095"  
2-1/2" x 0.095"  
Larger thicknesses may be approved at the High Limit Official's discretion.
- g) Titanium front axles, nerf bars and/or rear bumpers will not be permitted. Nerf bars and rear bumpers must be made from magnetic steel and/or stainless steel. The bumpers must be a minimum of one (1) inch in diameter and have a minimum material thickness of .065 inches. The nerf bars must not extend past the outside edge of the tires. All left and right side nerf bars must attach to the chassis at 3 points. 2 point side nerf hoops will no longer be allowed. For any car to be pushed off at any time the rear bumper must be in place behind the tail tank.
- h) All axle tethers will be required to attach to the front engine plate post or the rear bolt of the front radius rod and not the radiator post.

- i) Approved front axle tether systems are mandatory. The tether mounting must meet the SFI 55.1 specifications which includes two (2) Vectran® HS V-12, or Dynemma 12 tethers attached to the chassis. Tether systems must include a “king pin to king pin” tether that will attach to the axle clamp/band. Tether systems should be installed using the manufacturer’s provided fasteners. Tether systems of any type must be pre-approved and installed in accordance with the manufacturer’s instructions. All axle tether systems required clamping to or wrapping around the axle per the manufacturer’s instructions. The approved axle tethers may be revised from time-to-time with additional approvals and/or other changes to the approved list.
- j) All radius rods shall be constructed as a solid piece of round tubing with provision for a rod end on each end. No addition to the radius rod will be allowed. Radius rods must be attached to the frame and axle in a stationary manner. Devices that are designed to change the length or position of the radius rod in any way while the car is moving will not be allowed.
- k) The front bumper must not extend more than eight (8) inches from the frame and/or the measurement from the center of the front axle to the front of the front bumper must not exceed 23.5 inches.
- l) The top of the roll cage shall have a maximum outside width of 29.5 inches. Bracing that would prevent the driver’s ability to exit through the opening and/or inhibit safety/rescue workers ability to extract the driver will not be permitted.
- m) The cockpit horizontal middle frame bar will have a maximum outside width of 32.0 inches.
- n) The bottom frame rail will have a maximum outside width of 26.5 inches.
- o) All tubing utilized in the construction and/or fabrication of the main frame must be round in shape. Any other shapes, such as elliptical (oval) tubing will not be permitted.
- p) Only steel, carbon fiber or aluminum floor plans will be permitted.
- q) The minimum wheelbase will be 83 inches. The maximum wheelbase that will be permitted will be 90 inches.
- r) Front anti-roll torsion bar assemblies (sway-bars) will not be permitted.
- s) All cars must have a driveline strap and/or a driveline hoop restraint constructed of a minimum of .065 inch magnetic steel either welded and/or bolted to the chassis. The rear cross member used for mounting the steel driveline hoop must be constructed of .083 inch steel.
- t) Wings, bumpers and/or nerf bars must be positively fastened with bolts & nuts, hitch pins and/or roll pins only.
- u) The only chassis and/or frame adjustable device will be one (1) top wing adjuster for the top-wing slider mechanism. The slider must be one dimensional and allow forward and rearward movement only.
- v) The following frame measurements are minimum dimensions. Only those areas indicated are mandatory and subject to technical inspections. In lieu of the “BUTT” BAR a car’s rear end can be tethered to the rear chassis. ASTM4130 normalized steel or equivalent material is suggested. See drawing 16.5 A,S.

TOP RAILS 1-1/2" x .095"  
 BOTTOM RAILS 1-3/8" x .095" or 1-1/2" x .083"  
 ROLL CAGE UPRIGHTS 1-3/8" x .083"  
 ROLL CAGE CROSSMEMBER 1-1/2" x .095"  
 UPPER RAILS 1-3/8" x .083"  
 REAR END SAFETY "BUTT" BAR 1" x .083" or 1-1/4" X .065"  
 BRACE 1-1/4" x .065"

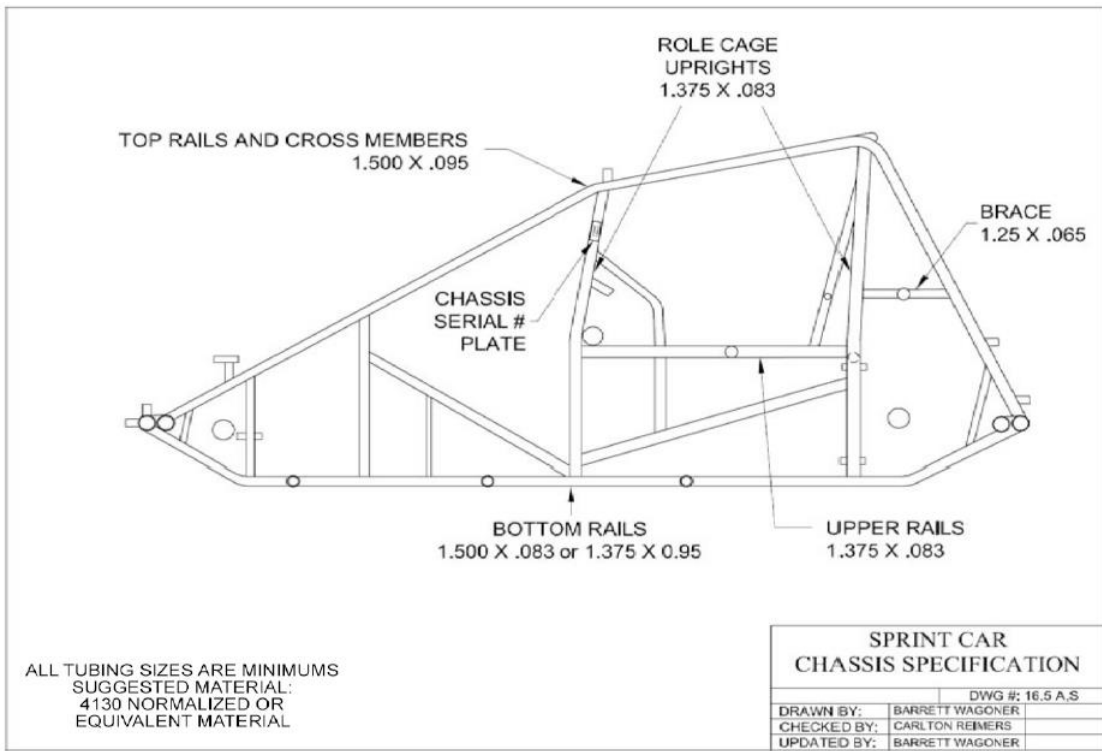

w) Torsion arm stops will be mandatory on both sides of the front torsion bars. The retainer may be of the rod-type with a securing cap or insert with an expanding mandrel and/or any other approved Torsion arm stop design. Torsion arm stops must be installed and used in accordance with the manufacturer's instructions.

The following torsion bar stops(s) have been approved for competition:

- Moose Block 1200 Retainer Kit
- All Star Performance All Star 10730 Retainer
- Maring Safety Retainer
- Butlerbuilt Mandrel
- KKR grove and clip
- Kaeding Clip
- DMI – T-REX (Torsion Restraint Express System)
- Schroeder Part number "BARS" (for Schroeder bars with relief in ends)
- Schroeder Part Number: "RWLAR" (Wedge Lock)

The approved Torsion Arm Stop may be revised from time-to-time with additional approvals and/or other changes to the approved list.

- x) Chassis Support Bars: All chassis are required to have additional bars installed to support and decrease the span between the front and rear uprights in the driver's area. The support bars must be in addition to the front and rear uprights. Any attempts to manipulate the front and rear uprights to conform to these measurements will not be allowed at the discretion of High Limit Officials.

These additional bars will be a minimum 1.375" x .083" ASTM4130 normalized steel or equivalent material.

Left and right-side support bars may be one of the three designs below.

Left and right-side support bars do not have to be of the same design.

Right side body opening shall remain the same 10 inches vertical and 21 inches horizontal at any point, with the exception of the 1-3/8" support tubing in place.

Left and right side support bars may be one of the three options:

1. Support bar may be designed similar to what was known as a "safety bar." It must be attached to the top rail at a point 15 inches to 20 inches from the rear of the front upright. It must attach to the hip rail and have a gusset attached to the rear upright near a point opposite of the rear brace/shock mount bar. The curve must be between 4 inches and 7 inches measured from outside of the rear upright tube to the outside of the support bar. See drawing 16.12.1.
2. Existing chassis with a left side support bar installed (formerly called safety bar) that do not meet the option one specification above, may add a gusset that attaches to the top rail 15 inches to 20 inches from the rear of the front upright and angle to the support bar. The existing support bar tubing must meet the minimum as described above 1.375" x .083" ASTM4130 normalized steel or equivalent material. See drawing 16.12.2.
3. A support bar may be added to the top rail at a point 15 inches to 20 inches from the rear of the front upright and to the rear upright near a point of the rear brace / shock mount bar but no higher than 7 inches above the hip rail. This bar may have a slight curve near the rear upright to accommodate elbow room and ease of fitment. See drawing 16.12.3.

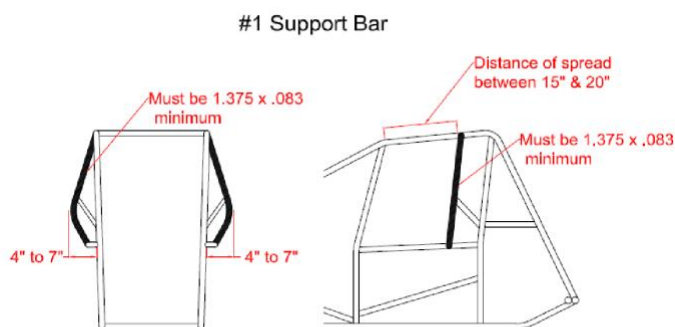

Diagram 16.12.1  
By Tom Devitt

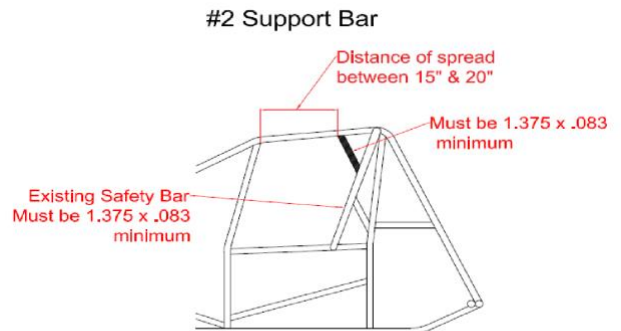
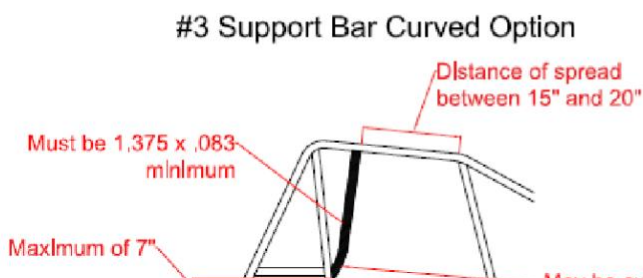

Diagram 16.12.2  
by Tom Devitt





## **6. Weight**

- a) All racecars must weigh a minimum of 1425 pounds with a driver fully prepared to compete in the car throughout an entire event.
- b) Additional bolt-on weight will be permitted, but must be mounted and fastened to the frame and/or chassis in a secure manner. All additional bolt-on weight must be mounted and fastened in the area between the bottom frame rails and axles but mounted no higher than the upper rails. At the discretion of High Limit Officials additional bolt-on weight may be mounted and/or fastened forward of the front axle, but not past the front torsion bar. All bolt-on weight must be white and have your car number clearly marked on it.

## **7. Body**

- a) Only standard type Sprint Car bodies, tails and hoods will be permitted.
- b) Side foils, rudders and/or panels that extend beyond the rear of the cage support bars will not be permitted.
- c) Nose pieces and/or the top portions of the hood must not extend forward of the leading edge of the front torsion tube or similar position on a coil-over car. Torsion tubes must be positioned in what is considered a conventional location. The hood side paneling or other side body pieces must not extend forward of and/or below the front axle.
- d) Sunshields are permitted. Sunshields cannot extend beyond the down tubes of the car or restrict the driver's vision, restrict driver's exit, or direct air all at the discretion of the High Limit Officials. The maximum height is 9 inches and no dish visors or wicker bills are allowed.
- e) Wedges and/or foils underneath the racecar will not be permitted.
- f) Pieces that are added to the basic frame to resemble, imitate and/or be specifically designed to deflect, trap and/or form a pattern for air to travel in a directed manner, except for those used to cool and/or protect the motor and the brake system, will not be permitted.
- g) Mirrors of any kind, whether attached to the racecar and/or the driver, will not be permitted. All cars must have a minimum of an 18-inch-tall number on the outside of both top wing panels and a minimum 18 inch tall number on the top wing center foil. Any letter utilized as part of the car number must be a minimum of 12 inches tall. If there are cars at any event that carry duplicate car numbers then one of the two cars will be required to add a letter to the number for scoring purposes.
- h) All cars will be required to run a full sprint-type appearing hood with a maximum outside hood width of 30 inches. The hood must extend to the front of the torsion tubes and/or similar location on coil-over cars. The hood may be a multiple piece design, but visually, it must appear to be one continuous piece in side-to-side and front-to-back manner.
- i) The driver's right-side opening must be a minimum of 10 inches vertical at any point and a minimum of 21 inches horizontal at any point. See Drawing 16.7.J. The left side paneling may extend to but not forward of the support bar. See Drawing 16.7.K. The use of a left side arm guard as part of the paneling is acceptable as long as it or any other part of the paneling does not prevent left-side driver entry or exit at the discretion of High Limit Officials.



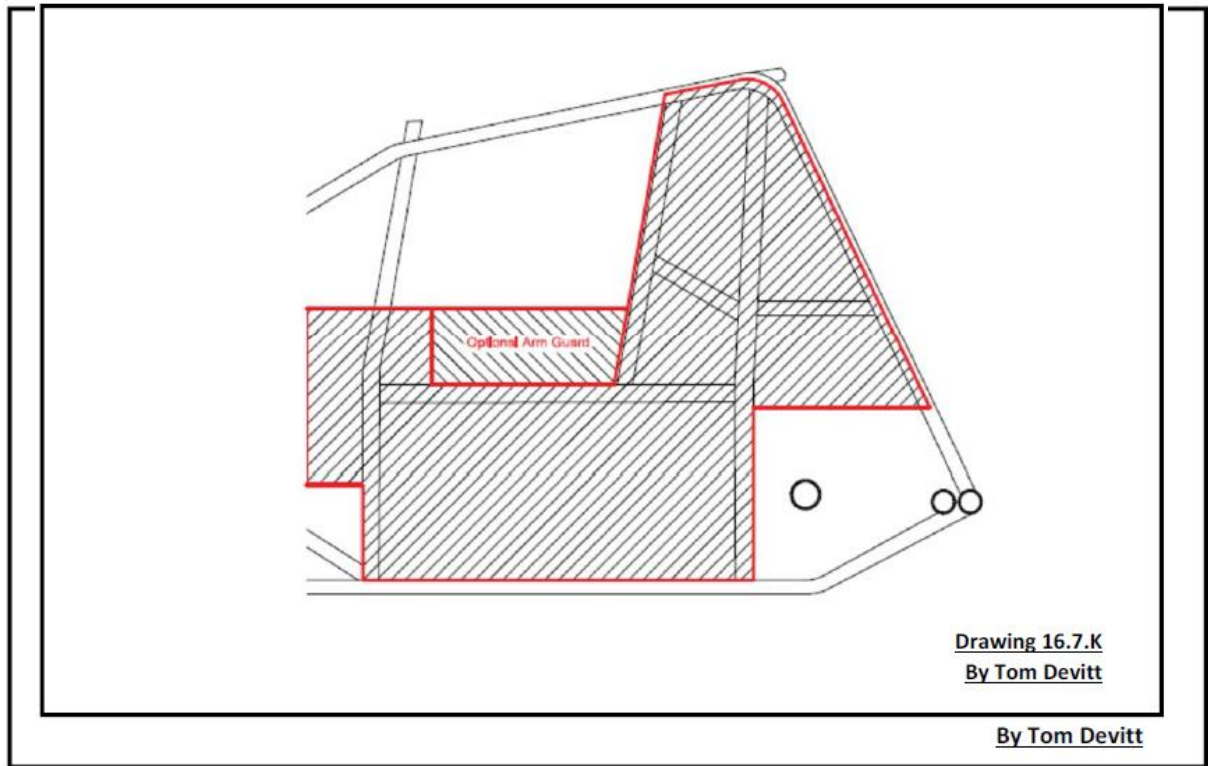

- j) Safety bar(s) and/or arm guard paneling that protrude outward from the frame rails for the purpose of creating room for the driver will be permitted. The guard(s) and/or paneling will be permitted to extend a maximum of 7 inches as measured from the outside edge of the middle frame rails and must remain above the middle frame rail. The sole purpose of this area is creating elbow room for the driver. The elbow room must remain above the upper “middle” frame rail and may not extend rearward of the leading edge of the rear axle.
- k) Rear radius rod protectors will be permitted. The maximum protector vertical opening will be 10 inches in height by 24 inches long and it must not extend more than 3-1/2 inches from the outside edge of the bottom frame rails.
- l) A maximum 1-1/2 inches wide by 20 inches long exhaust fume deflector, located on the bottom side-body panel at the rear edge will be permitted. The turnout angle must not exceed 90 degrees.
- m) All other side paneling must be fabricated flat and must not extend past the outside edge of the frame rails more than the thickness of the paneling material.
- n) Side body panel designs and/or concave surfaces that, in the sole discretion of the High Limit Officials, are intended to trap, alter and/or direct airflow for the purpose of gaining an aerodynamic performance advantage will not be permitted.
- o) Any new body designs including, but not limited to side body panels, hood design, nose pieces and/or any other part of the exterior body must be approved by the High Limit Officials prior to being introduced into competition.



## **8. Wings**

### **a) Top Wing Center Foil**

- i. Center Foil maximum size of 25 square feet with a maximum depth/thickness of 9 inches and a maximum length of 60 inches. Center Foil must be square or rectangular in shape with all 4 corners set at 90-degree angles with no variance allowed. Center foil top is to be flat from front to back and side to side. The center foil top must start being flat within 6 inches from the center foil's front leading edge. See Drawing 16.8.1.E at the end of this document.
- ii. Center Foil shall be fully sheathed in aluminum. Vent holes, dimples, ridges and/or any other type of fabricated modification will not be permitted anywhere on the wing.
- iii. A maximum 1.5 inch removable wicker bill may be mounted on the rear edge of the center foil. Wicker bill must be 90 degrees to the top of the center foil. Built-in wicker bills or gurney lips will not be permitted. The maximum dimension of wicker bill may change periodically at the discretion of High Limit Officials. Any such changes will be issued in writing prior to the event in which the change will be made. Front wing wicker bill remains at 2 inches.
- iv. The top wing may be adjustable in the cockpit by the driver. Other than the slider mechanism, moving parts will not be permitted on or in the foil structure.
- v. Only one slider mechanism will be permitted on the top wing, which only permits forward and backward adjustment.
- vi. Underneath side of center foil must appear to be a continuous smooth arc with no recesses, concaves, or protrusions. Center Foil must be one piece construction. Split or bi- wings will not be permitted. Only wings fabricated of metal alloys will be permitted. Fiberglass, carbon fiber and/or other similar material(s) will not be permitted in the basic framework of the wings. The top wing must not extend beyond outside of rear tires.
- vii. Foils or rudders will not be permitted anywhere on the top wing.
- viii. Wing T-Post will be built from 1" x .083" minimum ASTM4130 normalized steel or equivalent material. Wing attachment designs will be subject to approval. The only cast pieces approved will be HRP Part #HRP8811-A75-HD. If new T-Post designs are developed they must be submitted for approval. See Drawing 16.13.1.

## Wing T-Post

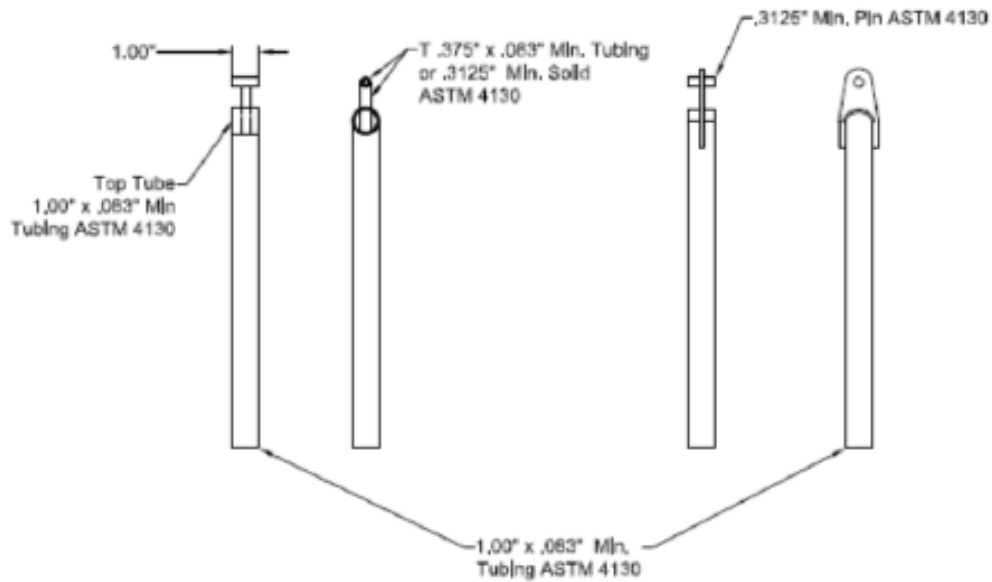

Drawing 16.13.1  
by Tom Devitt

### b) Nose Wing Center Foil

- i. The center foil will have a maximum size of 6 square feet with a maximum width of 36 inches and a maximum length of 24 inches. The center foil must be square or rectangular in shape with all four corners set at 90 degree angles. See Drawing 16.8.2.K at the end of this document.
- ii. Center foil shall be fully sheathed in aluminum. Vent holes, dimples, ridges and/or any other type of fabricated modification will not be permitted, anywhere on the wing.
- iii. A maximum 2-inch removable wicker bill may be mounted on the rear edge of the center foil. The wicker bill must be 90 degrees to the top of the center foil. Built-in wicker bills or gurney lips will not be permitted. The maximum dimension of wicker bill may change periodically at the discretion of High Limit Officials. Any such changes will be issued in writing prior to the event in which the change will be made.
- iv. The maximum distance from the center foil front edge to the front edge of the front axle may not exceed 20 inches.
- v. The center foil front edge must remain at least 1 inch behind the front edge of the front bumper. The center foil top surface from side to side must remain flat.
- vi. The center foil must be one piece. Split or bi-wings will not be permitted.
- vii. Only wings fabricated of metal alloys will be permitted. Fiberglass, carbon fiber or other similar material(s) will not be permitted in the basic framework of the wings.

- viii. The nose wing must not extend beyond the outside of front tires. The nose wing may not be cockpit or driver adjustable while the car is stationary and/or in motion.
- ix. Moving parts will not be permitted on or in the foil structure. Rudders or fins will not be permitted.
- x. The 5-inch section located at the rear of the front foil must not have a belly/curl arc that is out of proportion with the rest of the front foil. As measured on a 5-inch straight edge, the belly at 2-1/2 inches from the rear of the foil may not be deeper than 3/8 inch with no tolerance. It is suggested that the wing blueprint specify 11/32-inch depth, so that if any deflection or movement of the wing occurs, the depth will not exceed the 3/8 inch specification. (This 3/8-inch measurement ensures that the belly/curl arc is gradual).
- xi. The belly/curl arc must span the entire length of the front foil and appear to be a gradual arc with the deepest point, not further back than 12 inches from the leading edge. The belly/curl arc must start at the front foil's leading edge and shall not exceed a depth of 2 inches. Front foil thickness cannot exceed 3.6 inches.

**c) Side Board Panels**

- i. All braces or supports shall be oriented thin edge to face the air stream. Only rectangular, round or oval metal braces not exceeding 1 inch in width will be permitted. Adjustable bracing will not be permitted.
- ii. Aero elliptical brace material will not be permitted.
- iii. Brace or support shall not resemble a wicker bill or a split wing Side boards must be mounted square to the center foil and parallel to each other. Any kick-out will not be permitted.

**d) Nose**

- i. The nose side board's maximum size will be 26 inches long and 12 inches tall with an overhang not exceeding 1 inch from the center foil front edge to the side board front edge.
- ii. Side boards may have a maximum 1/2-inch front, back, top and bottom turnout(s) (flange).

**e) Top**

- i. The Top wing side board's maximum size will be 72 inches long and 30 inches tall. The top 2/3's of each top wing side panel shall consist of only 2 corners. Each corner shall be set at a 90-degree angle with no variance. This portion of the side panel's leading edge may not be behind the center foils leading edge.
- ii. Panels must be of one-piece construction.
- iii. Panels must be fabricated flat. Turnouts on all edges of the wing must not exceed 1-1/4" x 1-1/4" and must be orientated at a 90-degree angle to the flat portion of the side panel. Both top wing side boards should be at a 90-degree angle from the center section at any point. If wing panel(s) become damaged, repairs must be made before the car can compete in the next event.

In the event that there are new wing/foil components and/or a new wing/foil configuration they must be submitted per the High Limit Sprint Car Series Rule Book prior to being introduced into competition for approval.

## **9. Wheels/ Wheel Covers**

- a) The maximum width for the right rear wheel will be 18 inches. The maximum width for the left rear wheel will be 15 inches.
- b) The maximum wheel diameter will be 15 inches.
- c) Only steel or titanium wheel cover fasteners will be allowed.
- d) Plastic and/or carbon fiber wheels will not be permitted.
- e) Both 5 and 3 mounting point wheel covers will be allowed for competition under the following conditions. Wheel covers having a minimum of 5 attachment points may continue to use dzus fasteners. Said dzus fasteners must be made of magnetic steel or titanium only. Wheel covers having only 3 attachment points must be bolted-on at all 3 points utilizing a minimum 5/16 inch, flanged magnetic steel or titanium bolt and an approved fastening (nut assembly) system.
- f) Optional fastening systems that are equal or superior to the above approved system will become available as the season opens and will be looked at for approval before competition.
- g) Approved fastening (nut assembly) systems:
  - Keyser Manufacturing, Part #100 7-101
  - Wehrs Manufacturing Part # WM377A-312 (Aluminum 5/16)
  - Wehrs Manufacturing Part # WM377S-312 (Steel 5/16)
  - Triple X Chassis Part # SC-WH-7810 (for a 1" spring)
  - Triple X Chassis Part # SC-WH-7820 (for a 1-3/8" spring)
- h) Digital air bleeders are allowed, but cannot be operated remotely. Air may be introduced to the tire from an on board system. Any on-board system must be mounted inside the rear axle tube. It cannot be operated remotely.

## **10. Tires**

- a) Only the following designated Hoosier Racing Tires will be permitted for competition on all four (4) positions of the racecar at all High Limit Sprint Car Series events. The designated tire(s) will be available in the following compounds:

### **Front:**

85/8.0-15      D12, D15, D20

### **Left Rears:**

15.0/92-15      D12A  
15.0/93-15      D12A  
15.0/94-15      D12A  
15.0/96-15      D12A

**Right Rears:**

105/16.0-15 D15A, Medium

b) The altering of any tire compound, by any means, will not be permitted. Chemical alteration of the tread carcass and/or tread compound, such as tire 'soaking' and or the introduction of tread 'softener' and/or the physical defacement (removal, altering and/or covering) of tire sidewall markings in any manner will not be permitted. If any Competitor is found to have altered their tires any penalty deemed appropriate by High Limit Officials may be issued, up to and including a minimum suspension that includes all Events remaining in the High Limit Sprint Car Series racing schedule for that season. The rear drive tires may be protested by another competitor following the protest rules under Section 1.2.

i. Any tire may be inspected and/or analyzed for alteration at any time. This will consist of a process as determined by the independent laboratory that performs the analysis. A "Chain of Custody" process will be outlined with the Competitor upon inspection of the tires.

ii. The analysis process will require shipment of the tire to the selected laboratory. Additional race event(s) may be completed before a determination is made. If a penalty is issued, the event(s) that fell into the analysis time period while the tire(s) were being analyzed will be considered as part of the penalty time period.

c) Rear tire dimensions must comply with the High Limit Sprint Car Series dimensions. Both rear tires must freely fit the High Limit Sprint Car Series gauges during pre and/or post-race inspection.

d) During the RR Tire Enforcement Period, the right rear tire may only be changed to replace a punctured, damaged, sliced and/or out-of-round tire.

e) A High Limit Official must be present when a marked and damaged right rear tire is replaced and/or a different right rear tire is fitted during the RR Tire Enforcement Period.

f) Any damaged right rear wheel may be replaced without penalty, but must utilize the same marked right rear tire. If the tire is flat and/or damaged then the rules governing the changing of the right rear tire must be adhered to.

g) The front and left rear tires and/or wheels may be changed at any time between races.

h) Defacing or altering, in any way, the tire manufacturers' brand name, logo and other tire compound/size information is not allowed.

i) Any legal right rear tire may be used for the start of the Heat race, Dash, C-Main or B-Main events.

j) If a car loses a right rear tire on its first qualifying lap, a new right rear tire can be fitted, but the car will be restricted to one (1) lap at the end of qualifying and can qualify no better than one (1) spot out of the heat race inversion.

k) If any team attempts to fit a new right rear tire prior to the A-Main to gain an advantage any penalty, including disqualification, is at the discretion of a High Limit Racing Official.

l) During preliminary Main events and the Dash, a flat and/or damaged tire may be changed during a caution period in the designated work area. The following rules apply to tire change during preliminary Main;

- i. The car will restart in the position and procedure of a car exiting the work area, behind all cars on the same lap, provided the replacement is made within work area time allowed.
  - ii. A replacement will only be allowed for damaged tires, flat tires and/or damaged wheels. This rule applies to all four (4) tires on the car.
  - iii. Prior to any work of replacement, positive approval for any replacement must be obtained from the High Limit Official assigned to the work area.
  - iv. A damaged tire is described as a tire; flat on the wheel, deflated, with extremely low air pressure or other circumstance. Loss of air must be due to an apparent puncture, hole, slice, cut, tread separation, extreme tire wear or similar situation.
  - v. The damaged tire can be replaced with a new tire of the same compound or harder.
  - vi. Damaged tires will be impounded by High Limit Officials for inspection.
  - vii. If any additional time is taken by the High Limit Officials to determine if the tire meets the damaged tire criteria, that time will be added to the work area time.
  - viii. A damaged wheel may also be changed, with a replacement tire, during a caution period in the designated work area under the same stipulations as stated in this Sub-section n (i-viii). A damaged wheel is described as bent or broken, bead lock bent or broken, broken or damaged center section. Malfunctioning bleeder valves or bleeder devices are not considered as a damaged wheel.
- m) Replacing Marked Punctured, Damaged, Sliced and/or Out-of-Round Tires, with similar used Tires:
- i. During the RR Tire Enforcement Period, punctured, damaged, sliced and/or out-of-round marked right rear tires may be changed to a suitable right rear used tire of the same size and compound without penalty. Cars changing to a used tire during the Heat race will restart the race at the rear of the field that is on the same lap. Replacement tires will be remarked by the High Limit Officials and the replaced tire shall be confiscated. Should a suitable used tire, as specified above, not be available a harder compound may be used at the discretion of the High Limit Sprint Car Series Director.
  - ii. In the time period between time trials and the start of heat races a punctured, damaged, sliced and/or out-of-round marked right rear tire may be replaced with a new tire of the same size and compound without penalty. Replacement tires will be remarked by the High Limit Officials and the replaced tire shall be confiscated.

## **11. Shocks**

- a) Only conventional and thru-rod style shock absorbers will be permitted. No additional components will be added to the torsion arm or other suspension components to help control the suspension, such as, but not limited to additional shocks, springs, spring arms, etc. Maximum of (1) shock per wheel, (4) shocks total. Any new style shock configuration or new suspension configuration must be approved by High Limit Officials prior to being placed into competition. Performance, safety, cost, along with other variables, will factor into the approval process. Current approved thru-rod style shocks: Penske – Part # PS-7700T

- b) One in-car shock adjustment will be allowed. The adjustment is for compression OR rebound settings OR both settings together with a single movement. A single adjuster that adjusts both separately is not allowed(no push/pull adjusters).

## **12. Other**

- a) Racing components in aluminum and magnesium should be checked for stress and replaced on a regular basis, based on the manufacturer's recommendations of the life usage of the part. These parts are, but not limited to, wheel centers, live rear axles, hubs and top wings.
- b) Computer operated and/or controlled parts, such as fuel injection, fuel systems, chassis adjusting systems, etc., will not be permitted at any time during any event. The use of any electronic remote and/or wireless equipment capable of adjusting any equipment and/or function on the race car during any type of racing competition will not be permitted.
- c) The use of electronic logic processors (this includes any traction control devices) to control any function of the racecar and/or any system for continuous gathering of data from any function of the race car for which the intended use is computer downloading will not be permitted at any time during any Event.
- d) Two-way radios, crew-member to driver and/or any other means of electronic communication, other than the one-way radio provided by the High Limit Sprint Car Series, will not be permitted.
- e) All cars shall be equipped and/or be capable of being equipped with a transponder (for lap scoring). Transponders shall be located in any area determined by the High Limit Officials. The fitted transponder box shall be mounted as close as possible to the ground, but not protrude below the frame rail. It is the responsibility of the Competitor to ensure that the transponder is in quality working condition, fully charged and is securely mounted and is in a suitable position with brackets as outlined above. Competitors may be required to leave their driver's license with the High Limit Sprint Car Series when they receive their transponder equipment. Should a team's transponder be lost, damaged, destroyed and/or not returned, the replacement cost of the transponder will be withheld from the team's purse winnings from that event. It is in everyone's interest that transponders are suitably and securely attached and are in good working condition.
- f) Competitors will be required to receive and use "one-way radio communication" from High Limit Officials. The communication from the High Limit Sprint Car Series Director will aid in the direction of the race, including, but not limited to, safety and resetting the race lineup prior to any restart. Drivers must always have their one-way radio on when on the racetrack for any reason.
- g) Electronics, Gauges and Dashes
  - i. 2-way communication devices in or attached to the race vehicle or on the driver's person will not be permitted.
  - ii. Cellular, satellite and/or Wi-Fi devices in or attached to the race vehicle or the driver's person will not be permitted. No cellular phones or smart watches are permitted at any time.
  - iii. Antennas will not be permitted in or attached to the race vehicle or carried by the Driver.
  - iv. All forms of a vehicle position system (GPS) will not be permitted.
  - v. Only approved lap timing and or lap time recording devices (transponders) will be permitted.

- vi. Gauges to monitor engine conditions are permitted at the discretion of High Limit Officials.
- vii. All electric gauges, whether analog or digital, except tachometers, will only be permitted to have one (1) input from the respective gauge sensor. Outputs from the gauges will not be permitted. Tachometers will be permitted to record engine RPM for recall.
- viii. Electronic Dash Modules will not be allowed.
- ix. All additional wiring harnesses related to Electronic Dash Modules or any other type of data acquisition must be completely removed from the race vehicle during an event.



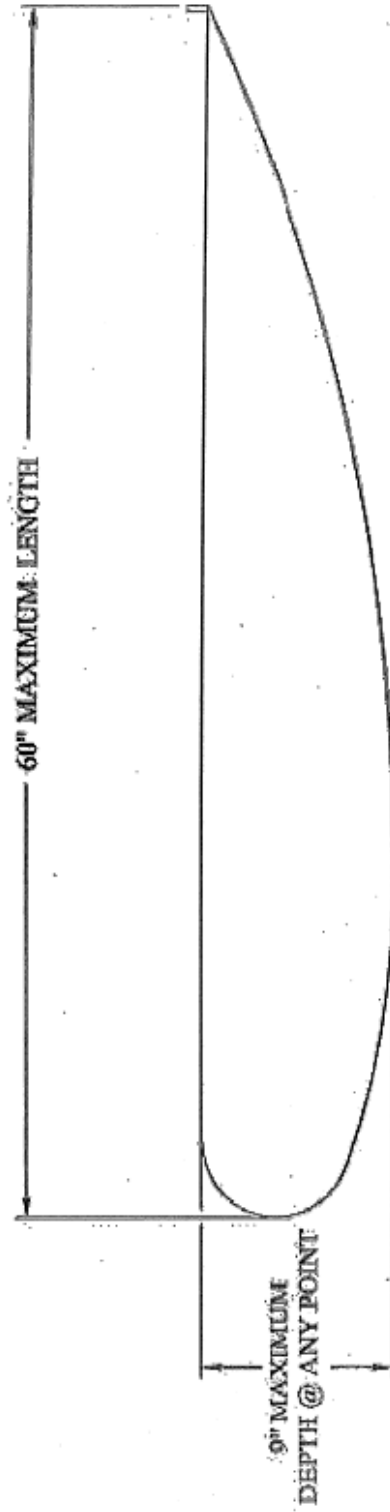

MAX. 2" WICKER BILL MAY BE MOUNTED ON REAR  
EDGE OF THE CENTER FOIL

**SPRINT CAR  
TOP WING  
CENTER FOIL**

	DWG #16.8.1.E
DRAWN BY:	BARRETT WAGONER
CHECKED BY:	CARLTON REIMERS
UPDATED BY:	BARRETT WAGONER